

TB 9-6625-2309-35

CHANGE 1

DEPARTMENT OF THE ARMY TECHNICAL BULLETIN

CALIBRATION PROCEDURE FOR OPTICAL FIBER TEST SET, TS-4320(P)/G

Headquarters, Department of the Army, Washington, DC
4 March 2004

Distribution Statement A: Approved for public release; distribution is unlimited.

TB 9-6625-2309-35, 5 August 1996, is changed as follows:

1. Remove old pages and insert new pages as indicated below. New or changed material is indicated by a vertical bar in the margin of the page.

Remove Pages

1 and 2
3 and 4
29 and 30

Insert Pages

1 and 2
3 and 4
29 and 30

2. File this change sheet in front of the publication for reference purposes.

By Order of the Secretary of the Army:

Official:



JOEL B. HUDSON

*Administrative Assistant to the
Secretary of the Army*

0400602

PETER J. SCHOOMAKER

*General, United States Army
Chief of Staff*

Distribution:

To be distributed in accordance with IDN 344581, requirements for TB 9-6625-2309-35.

TB 9-6625-2309-35

SUPERSEDED COPY DATED 25 JULY 1995

DEPARTMENT OF THE ARMY TECHNICAL BULLETIN

CALIBRATION PROCEDURE FOR OPTICAL FIBER TEST SET, TS-4320(P)/G

Headquarters, Department of the Army, Washington, DC
5 August 1996

Distribution Statement A: Approved for public release; distribution is unlimited

REPORTING OF ERRORS AND RECOMMENDING IMPROVEMENTS

You can improve this manual. If you find any mistakes or if you know of a way to improve these procedures, please let us know. Mail your letter or DA Form 2028 (Recommended Changes to Publications and Blank Forms) directly to: Commander, US Army Aviation and Missile Command, AMSAM-MMC-MA-NP, Redstone Arsenal, AL 35898-5000. A reply will be furnished to you. You may also provide DA Form 2028 information to AMCOM via e-mail, fax, or the World Wide Web. Our fax number is DSN 788-6546 or Commercial 256-842-6546. Our e-mail address is 2028@redstone.army.mil. Instructions for sending an electronic 2028 may be found at the back of this manual. For the World Wide Web, use <https://amcom2028.redstone.army.mil>.

SECTION		Paragraph	Page
I.	IDENTIFICATION AND DESCRIPTION		
	Test instrument identification.....	1	2
	Forms, records, and reports	2	2
	Calibration description	3	2
II.	EQUIPMENT REQUIREMENTS		
	Equipment required	4	2
	Accessories required	5	3
III.	CALIBRATION PROCESS		
	Preliminary instructions.....	6	4
	Equipment setup	7	4
	Horizontal scale error.....	8	10
	Attenuation scale non-linearity.....	9	16
IV.	CIRCUIT ALIGNMENT		
	A/D adjustments	10	27
	Installation and use of software level 1.08a	11	32
	Time insertion delay characterization	12	36
	Final procedure.....	13	44
APPENDIX	A Data sheets		A-1

*This bulletin supersedes TB 9-6625-2309-35, dated 25 July 1995.

CHANGE 1

**SECTION I
IDENTIFICATION AND DESCRIPTION**

1. Test Instrument Identification. This bulletin provides instructions for calibration of the Optical Fiber Test Set TS-4320(P)/G. Purchase/Description CR-PD-8018-001, dated 16 October 1989, TM 11-6625-3271-12, and TM 11-6625-3271-40 were used as the prime data sources in compiling these instructions. The equipment being calibrated will be referred to as the TI (test instrument) throughout this bulletin.

a. Model Variations. None

b. Time and Technique. The time required for this calibration is approximately 5 hours, using the dc and low frequency technique.

2. Forms, Records, and Reports

a. Forms, records, and reports required for calibration personnel at all levels are prescribed by TB 750-25.

b. Out-of-tolerance conditions to be reported are designated (R) at the end of the sentence in which they appear. When these conditions are in tables, the (R) follows the designated adjustment. Report only those out-of-tolerance-conditions designated with (R).

3. Calibration Description. TI parameters and performance specifications which pertain to this calibration are listed in table 1.

Table 1. Calibration Description

Test instrument parameter ¹	Performance specifications
Horizontal scale error	Range: 0 to 65 km Accuracy ² : $\pm 1 \text{ m} \pm (3 \times 10^{-5}) \times \text{distance}$ Range: 65 to 120 km Accuracy: $\pm 10 \text{ m} \pm (3 \times 10^{-5}) \times \text{distance}$
Attenuation scale non-linearity	Range: 0 to 5 dB Accuracy: $\pm 0.5 \text{ dB}$ over entire dynamic range

¹Optical modules TD-260C, TD-261C, and TD-285C.

²Accuracy includes data point sampling error of 0.5 m.

**SECTION II
EQUIPMENT REQUIREMENTS**

4. Equipment Required. Table 2 identifies the specific equipment to be used in this calibration procedure. This equipment is issued with Secondary Transfer Calibration Standards Set AN/GSM-287, or AN/GSM-705. Alternate items may be used by the calibrating activity. The items selected must be verified to perform satisfactorily prior to use and must bear evidence of current calibration. The equipment must meet or exceed the minimum use specifications listed in table 2. The accuracies listed in table 2 provide a four-to-one ratio between the standard and TI. Where the four-to-one ratio cannot be met, the four-to-one accuracy will be listed and the actual accuracy of the equipment selected is shown in parenthesis.

5. Accessories Required. The accessories listed in table 3 are issued as indicated in paragraph 4 above and are used in this calibration procedure. When necessary, these items may be substituted by equivalent items, unless specifically prohibited.

Table 2. Minimum Specifications of Equipment Required

Common name	Minimum use specifications	Manufacturer and model (part number)
FOCUS-SWCM	Range: 850 nm Accuracy: ±5 nm Insertion delay ¹ : ±0.25 m (±0.56 m) Switched attenuation uncertainty: ±0.02 dB	Nichols Research Corp. Model 202-60018-02 (202-60018-02)
FOCUS-LWCM	Range: 1310/1550 nm Accuracy: ±5 nm Insertion delay ¹ : ±0.25 m (±0.56 m) Switched attenuation uncertainty: ±0.02 dB	Nichols Research Corp. Model 202-60018-01 (202-60018-01)
DIGITAL DELAY/PULSE GENERATOR	Range: 10 to 1000 µsec Accuracy: 1500 psec + 1 x 10 ⁻⁶ x delay	Stanford Research Systems Inc. Model DG535 w/option 03 (DG535w/OPT03)
LIGHTWAVE MULTIMETER	Range: -5 to -50 dBm Accuracy: ±5.0% Non-linearity: < 1%	Hewlett Packard Model 8153A (8153A) with plug-in 81531A (81531A) and ST connector adapter PN 81000VI (81000VI)
FREQUENCY COUNTER	Range: 25 MHz Accuracy: ±0.0025%	Fluke PM6681/656 (PM6681/656)
FIBER OPTIC TEST BOX	Time of flight (TOF) Accuracy: Test report value	NSN 6625-01-418-8818
MULTIMETER	Range: 0.009 to 2.000 V dc Accuracy: ±0.00225 V dc	Hewlett-Packard, Model 3458A (3458A)

¹Combined uncertainties for FOCUS-LWCM or FOCUS-SWCM when used with digital delay/pulse generator is ±5.6 ns or ±0.56 m.

Table 3 Accessories Required

Common name	Description (part number)
TS-4320 Optical Fiber Test Set Calibration Software ¹	Version 1.0
Software Level 1.08a ²	Version 1.08a laser precision
Electrical Connector Assembly	NSN 5935-01-371-5251 (LPTF-1047)
Module Simulator Circuit Card Assembly	(LPTF-1056) Laser Precision
Electrical Test Extender Card	NSN 5998-01-371-1042 (LPTF-1048)

¹Calibration software and its instruction manual for TS-4320(P)/G Optical Fiber Test Set can be obtained from: Commander, U. S. Army Aviation and Missile Command, ATTN: AMSAM-TMD-LW, Redstone Arsenal, AL 35898-5000.

²Software level 1.08a obtained from AMSAM-TMD-LP.

**SECTION III
CALIBRATION PROCESS**

6. Preliminary Instructions

a. Instructions outlined in paragraphs 6 and 7 are preparatory to the calibration process. Personnel should become familiar with the entire bulletin before beginning calibration.

b. Items of equipment used in this procedure are referenced within the text by common name as listed in table 2.

c. Unless otherwise specified, verify the result of each test and, whenever the test requirement is not met, take corrective action before continuing with the calibration. Additional maintenance information is contained in TM 11-6625-3271-12 and TM 11-6625-3272-40 for this TI.

d. Unless otherwise specified, all controls and control settings refer to the TI.

7. Equipment Setup

WARNING

HIGH VOLTAGE is used or exposed during the performance of this calibration. DEATH ON CONTACT may result if personnel fail to observe safety precautions. REDUCE OUTPUT(S) to minimum after each step within the performance check where applicable.

WARNING

Always keep end of a fiber optic cable 1 foot away from eyes. Never look into end of an energized fiber optic cable

NOTE

If FOCUS-SWCM optical subassembly (PIN 202-60015-01), FOCUS-LWCM optical subassembly (PIN 202-60015-02), or DG535 digital delay/pulse generator have been repaired or replaced, time insertion delay (T_{ID}) may have changed. Steps in paragraph 12, SECTION IV, must be performed for verification.

NOTE

Record optical module and TI mainframe serial numbers on data sheet. Optical module serial number is located on back of assembly. Now is a good time to record each optical module serial number.

CAUTION

Do not remove optical modules with power on or damage to optical module may occur.

a. Position TI **ON-OFF** switch to **OFF**. If TD-260C optical module is not presently installed in TI optical module compartment, remove existing optical module and install TD-260C optical module.

NOTE

If software level 1.08a is installed, ZERO-KM SETTING may be set to other than 0 nanoseconds. Perform steps in Section IV, paragraph **11c**, record present value of ZERO-KM SETTING, then change ZERO-KM SETTING to **0**. Restore recorded values of ZERO-KM SETTING after performing steps in **b** below.

NOTE

On cold power up TI will sometimes lock on wrong sync pulse during self-zeroing. Steps in **b** below should be performed to check for slope on leading edge of *dead zone pulse*. Slope must be present for proper operation of horizontal scale measurements.

b. Perform steps (1) through (5) below:

(1) Perform steps (a) through (c) below:

(a) Set TI **ON-OFF** switch to **ON** and allow TI 5 minutes to warm up and stabilize.

(b) Set TI **ON-OFF** switch to **OFF**.

(c) Set TI **ON-OFF** switch to **ON**.

NOTE

TI has a screen saver feature which causes display to be turned off after a short period if no entries are made to front panel. Press any pushbutton to restore screen.

(2) After TI does self-test and displays **Press Any Main Panel Key to Begin**, press any front panel pushbutton.

(3) Press **FAST SCAN** pushbutton. Wait for **LASER ON/AVG** on display indication to go off.

(4) Press **HOR EXP** pushbutton as necessary to view slope on leading edge of *dead zone pulse*. Slope must be present and in approximate position shown in figure 1.

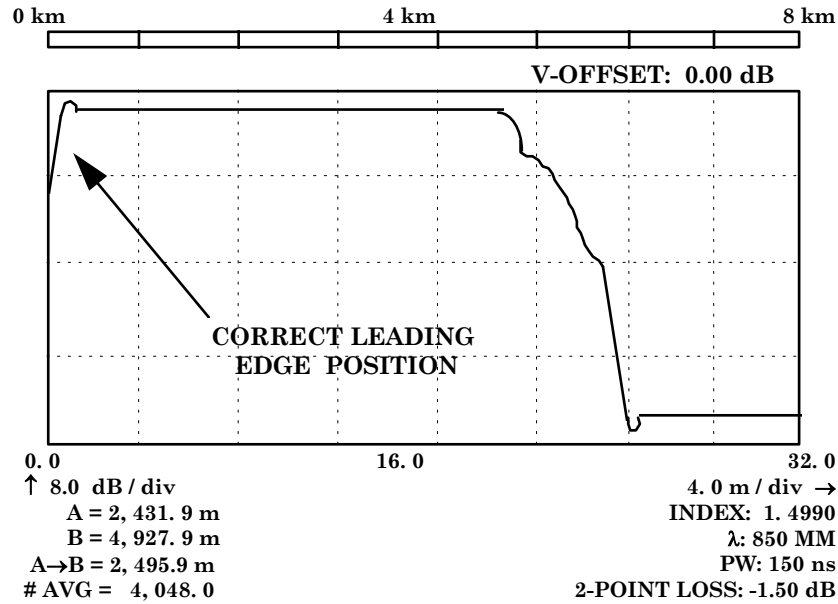

Figure 1. Example of correct leading edge position of *dead zone pulse* (TD-260C).

(5) If leading edge is not visible or is located to right of the origin (dashed lines, figure 2), set **ON-OFF** switch to **OFF** and repeat steps (1) through (4) above.

c. Connect equipment as shown in figure 3, CONNECTION A. Connect optical fiber jumper cable from FOCUS-SWCM OPTICAL I-O to ST CONNECTOR ADAPTER attached to OPTICAL INPUT of LIGHTWAVE MULTIMETER (fig. 3).

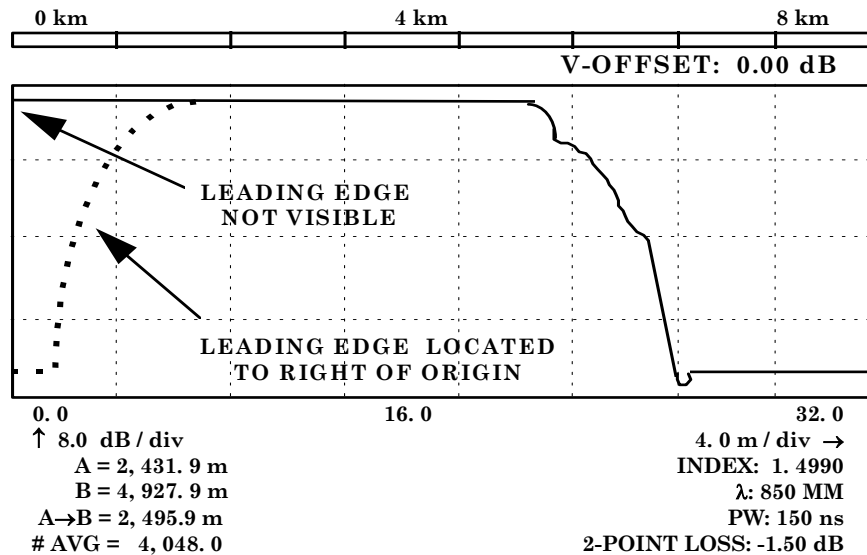

Figure 2. Example: Example of incorrect leading edge position of *dead zone pulse* (TD-260C).

NOTE

FOCUS standards which were used to measure T_{ID} as reported on FOCUS Insertion Delay Measurement Worksheet must not be interchanged with other FOCUS standards nor optical fiber jumper cable lengths changed from those shown in figure 3. Doing this may change time insertion delay and affect software calculations. If different optical fiber jumper cable lengths must be used, a 1.0 meter change in length is equal to approximately 10 nanoseconds change in insertion delay.

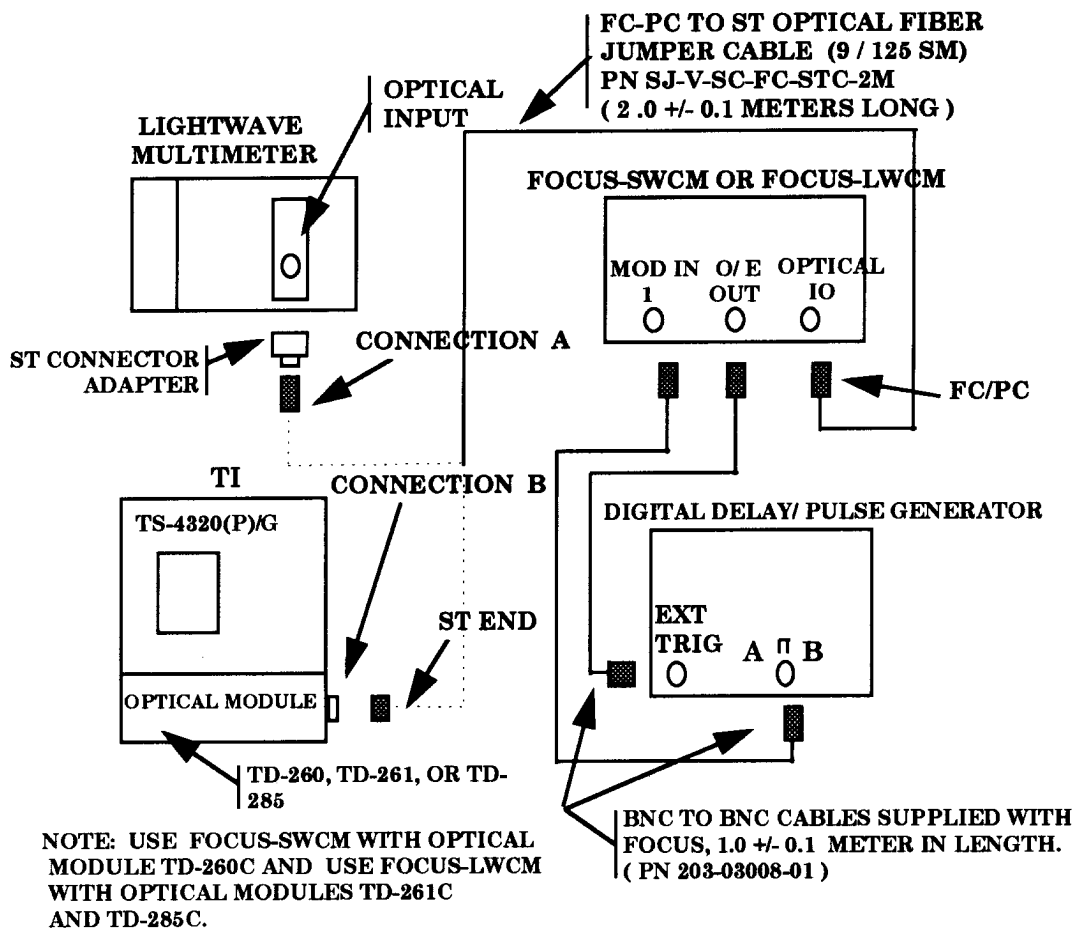

Figure 3. Horizontal scale error - equipment setup.

NOTE

Optical fiber connectors used with this equipment have high precision optical surfaces which mate two optical fibers accurately. It is good practice to periodically clean the ceramic ferrule (ends of optical fiber jumper cable) with reagent grade alcohol on an optical grade lintless tissue. Dry connector end with a dry (optical grade) lintless tissue. Connector should be carefully handled to avoid contamination or damage when unprotected by its dust cap. Replace connector dust cap when optical fiber jumper cable is not connected to equipment. Small amounts of dirt, dust, oil or other foreign matter on connector ferrules can cause abnormal attenuation or damage to the connector. Do not touch connector ferrule with unwashed hands as this deposits oil which acts as a sticky surface to attract dust, etc.

NOTE

Both FC-PC and ST connectors are keyed. Key on connector must be aligned with key slot on connector receptacle.

d. Perform (1) through (4) below:

- (1) Set **FOCUS-SWCM POWER OFF ON** key control switch to **ON**.
- (2) Press digital delay/pulse generator **POWER ON-OFF** pushbutton to **ON**.
- (3) Press lightwave multimeter power pushbutton to **ON**.
- (4) Allow 15 minutes for test equipment to warm-up and stabilize.

e. Set lightwave multimeter to measure optical power in dBm at 850 nm wavelength.

f. Perform (1) through (2) below:

- (1) Set **FOCUS-SWCM LD BIAS CURRENT** switch to **LD PULSED**.
- (2) Set **FOCUS-SWCM SWITCHED ATTN** switch to **OUT**.

g. Monitor lightwave multimeter and adjust **FOCUS-SWCM VAR ATTN 1** control for -27 ± 0.2 dBm optical power output.

NOTE

When calibrating TD-285C optical module, adjust **FOCUS-LWCM VAR ATTN 1** for -38 ± 0.2 dBm at 1310 nm and 1550 nm.

h. Carefully remove optical fiber jumper cable connector from lightwave multimeter and connect to fiber connector of TD-260C optical module (located on right-hand side under black rubber dust boot), CONNECTION B (fig. 3).

NOTE

Speed-up devices shown at figure 3-18, FOCUS Operation Manual, are optional. For purpose of this calibration procedure, speed-up devices are not required.

i. Set digital delay/pulse generator controls to settings as indicated in (1) through (12) below:

NOTE

Digital delay/pulse generator softkeys have more than one function depending on mode of operation.

- (1) Press **MENU TRIG** pushbutton to cycle through steps (2) through (5) below.
- (2) **TRIG** to **EXT**.
- (3) **THRESHOLDS** to **+0.50V**.
- (4) **SLOPE (+/-)** to **+**.
- (5) **TRIGGER TERM** to **50 OHM**.
- (6) Press **MENU OUTPUT** to cycle through steps (7) through (11) below.
- (7) **OUTPUT** to **AB**.
- (8) **AB & -AB LOADS** to **50 OHM**.
- (9) **AB: VAR**.
- (10) **AB: AMPLITUDE** to **+2.00V**.
- (11) **AB: OFFSET** to **-1.60V**.
- (12) Press **MENU DELAY** pushbutton to set **B Delay** to **B=A + 0.000010000000** (10 μ sec)

NOTE

Make copies as required of data sheets included at appendix A for recording data and software computations.

j. Record displayed index (from TI) on TD-260C Data Sheet (appendix A) at Customer Existing Index of Refraction line.

TB 9-6625-2309-35

k. Press **PULSE WIDTH** pushbutton to select **SHORT**.

l. While pressing **N/LASER** pushbutton, adjust **CURSOR A** control to set **INDEX:** to **1.4990** on TI display.

NOTE

If FOCUS-SWCM optical subassembly (PIN 202-60015-01), FOCUS-LWCM optical subassembly (PIN 202-60015-02), or DG535, digital delay/pulse generator have been replaced or repaired, T_{ID} may have changed. Steps in paragraph 12, SECTION IV, must be performed for verification.

8. Horizontal Scale Error

a. Performance Check

(1) Press **DISPLAY FROM** pushbutton to select **ORIGIN**.

NOTE

Softkeys have more than one function depending on mode of operation.

(2) Perform (a) through (h) below:

(a) Press **HELP** pushbutton.

(b) Press **MORE** softkey.

(c) Press **INSTRUMENT SETUP** softkey.

(d) Press **OTDR SETUP** softkey.

(e) Press **FIBER LEN/RES** softkey.

(f) Adjust **CURSOR A** control to display **NEW LENGTH & RESOLUTION** values to match **LEN/RES** values on TD-260C (850 nm) Horizontal Scale Data Sheet (first cluster) (appendix A).

(g) Press **ACCEPT CHANGES** softkey.

(h) Press **RETURN TO OTDR MODE** softkey.

(3) Press **DELAY** pushbutton as necessary to set digital delay/pulse generator for **A=T+0.000010000000** (10 μ sec).

NOTE

At **Index = 1.4990**, 10 μ sec **A = T+** delay corresponds to approximately 1.0 km location where leading edge of FOCUS generated pulse will occur on TI display; 20 μ sec to 2.0 km, etc.

NOTE

For optical module TD-285C, set digital delay/pulse generator for **A=T+0.000020000000** (20 μ sec).

(4) Perform steps (a) and (b) below:

(a) Press **REAL TIME** pushbutton and adjust **FOCUS VAR ATTN 1** control for minimum noise on trace prior to FOCUS generated pulse (fig. 4).

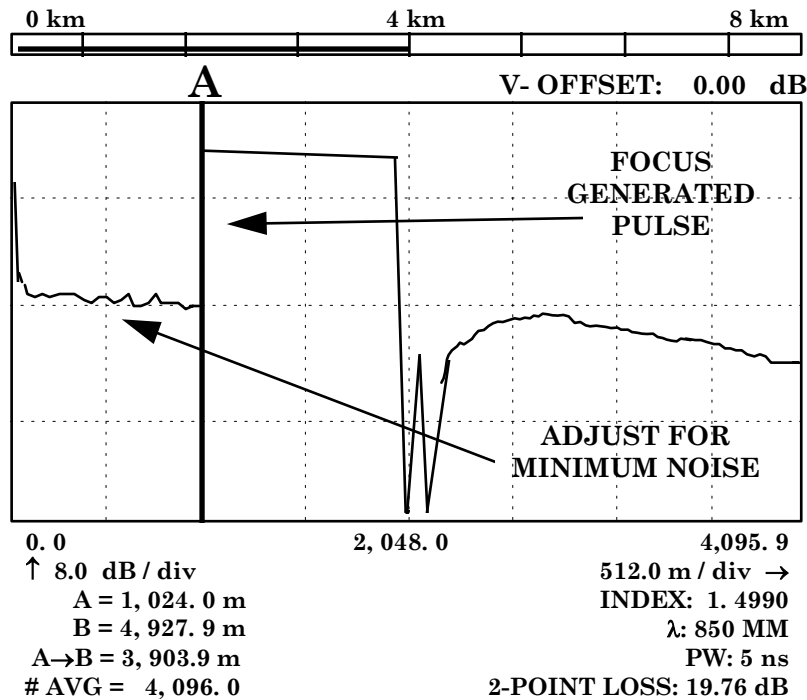

Figure 4. Example of cursor A at leading edge of FOCUS generated pulse (TD-260C).

(b) Press **FAST SCAN** pushbutton and wait for **LASER ON/AVG** indication on TI display to go off.

NOTE

Digital delay/pulse generator **TRIG** and **BUSY** lights will be illuminated during TI acquisition cycle indicating a good external trigger and equipment working correctly.

(5) Press **HOR CONT** pushbutton until FOCUS generated pulse is visible on TI display.

(6) Adjust **CURSOR A** control to place cursor A at leading edge of FOCUS generated pulse (fig. 4).

(7) Press **DISPLAY FROM** pushbutton to select A.

(8) Press **HOR CONT** pushbutton until FOCUS generated pulse leading edge is visible on TI display. Adjust **CURSOR A** control to place cursor A at leading edge of FOCUS generated pulse.

(9) Press **HOR EXP** pushbutton as necessary to display **2.0 m/div** (0.0020 km/div) on TI.

NOTE

It may be necessary to use different **HOR EXP** or **HOR CONT** and **VERT EXP** or **VERT CONT** pushbutton settings to obtain best waveform for accurate cursor placement.

(10) Press **VERT EXP** pushbutton as necessary to display **4.0 dB/div** on TI.

(11) Adjust **CURSOR A** control as necessary to position cursor A on FOCUS GENERATED PULSE LEADING EDGE STARTING POINT (fig. 5).

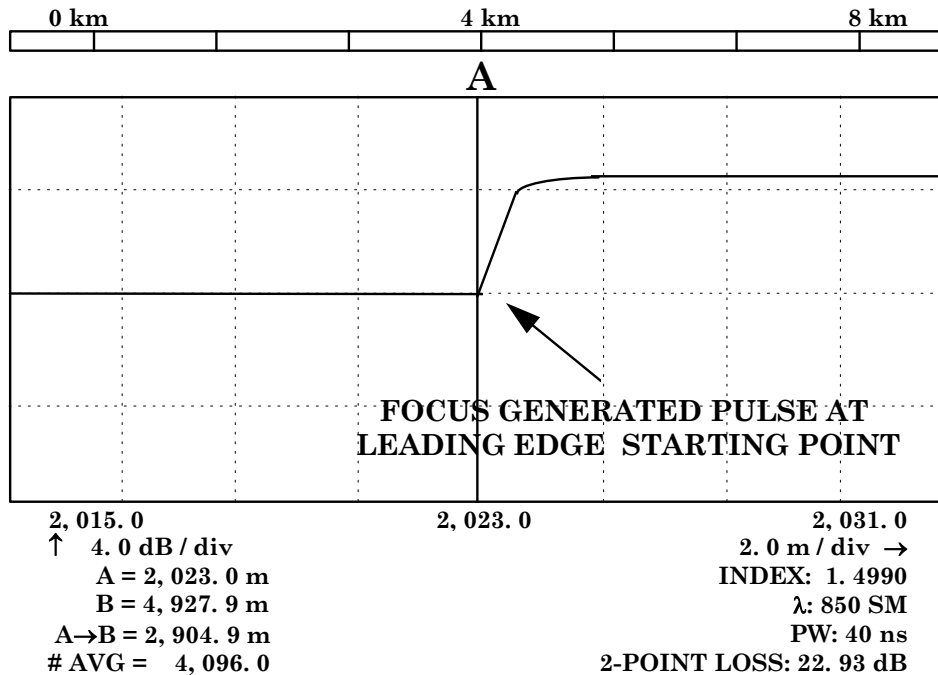

Figure 5. Example of cursor A on FOCUS generated pulse leading edge starting point (TD-260C).

NOTE

Accurate cursor placement to correct position on pulse starting point is required for good results. Some optical modules have been observed to display undershoot on trace prior to FOCUS pulse. If there is undershoot, adjust cursor to immediate beginning of FOCUS generated pulse after undershoot so undershoot is just below horizontal center graticule (fig. 6).

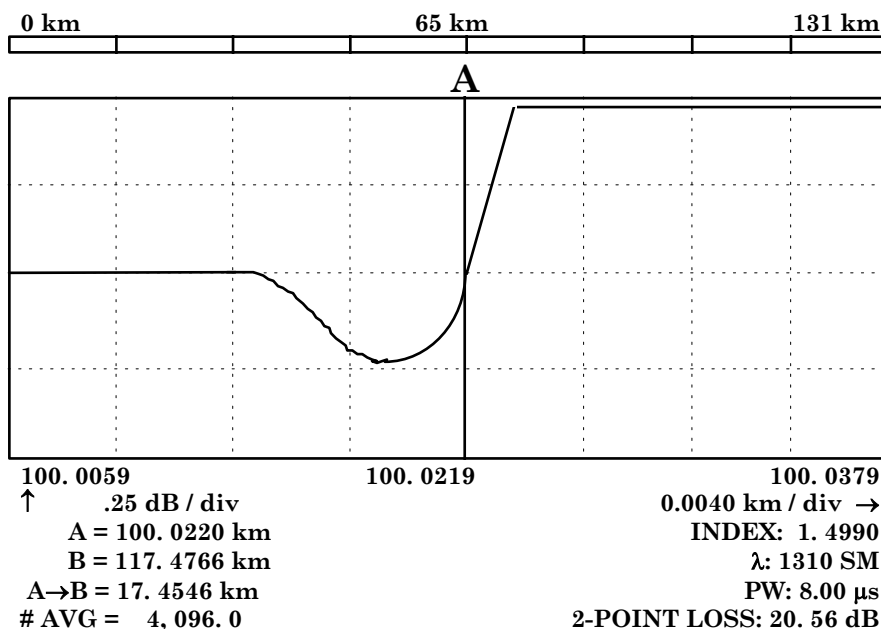

Figure 6. Example of cursor placement if undershoot is present (TD-285C).

(12) Record A= (in km) on TI display in A= (km) column on TD-260C Horizontal Scale Data Sheet (appendix A).

NOTE

Each change in digital delay/pulse generator A= T+ value will not produce a change in position of FOCUS generated pulse. Normally a series of A= T+ values, incremented in small constant positive steps, will result in same pulse positions up to a point. At this point the next A=T+ increment will cause pulse to shift to right of the cursor on TI display. This procedure requires the lowest A=T+ value which causes the FOCUS generated pulse to shift in position, resulting in a larger A= T+ indication. One shift is required for each cluster of data. When this shift occurs, no more data is required for that cluster. Shift magnitude will typically be 0.5 meter for first cluster (all optical modules); 2 meters for TD-260C, 4 meters for TD-261C, and 8 meters for TD-285C for second cluster.

TB 9-6625-2309-35

(13) Repeat technique of steps **a**(3), (4)(b), (11) and (12) for next digital delay/pulse generator A=T+ value on TD-260C data sheet (appendix A) (first cluster) until a shift to right of cursor A FOCUS generated pulse is observed. Record this A= km TI indication on data sheet. When shift occurs, this is the final measurement required for this cluster.

NOTE

Press TI **PULSE WIDTH** pushbutton to select **LONG** for second cluster measurements.

(14) Repeat technique of steps **a**(1) through (13) for second cluster using A=T+ values on TD-260C data sheet (second cluster).

(15) Load TS-4320 Optical Fiber Test Set calibration software to an MS-DOS compatible PC according to instructions in TS-4320, Calibration Software User's Manual.

(16) Access **Distance Scale Calibration** menu.

(17) Access data entry page and enter insertion delay and index of refraction (1.4990) for constants entry. On data edit page enter only last two digital delay/pulse generator settings for A=T+ (μ s) and respective TI A= (km) values for each cluster from TD-260C data sheet (appendix A).

NOTE

Time insertion delay (T_{ID}) is given in nanoseconds with each FOCUS unit on FOCUS Time Insertion Delay Measurement Worksheet. Time insertion delay may be different for each wavelength and FOCUS control module. Be sure to use correct insertion delay for control module and wavelength being used.

(18) Verify entered data is correct then quit data edit page.

(19) Select **Generate Report** and then **Graphic Report** screen to view resultant plot (fig. 7).

NOTE

Two dashed lines on graphical report represent boundaries of normally acceptable uncertainty for TI. Beyond 65 km, boundaries are increased to allow for additional tolerance at long range. If least squares line fitted to data points is outside these boundaries, TI is considered out of tolerance (data points outside of boundaries are acceptable). In this case, verify data entries and constants on data entry page. Repeat calibration before TI is adjusted or repaired. Select **Graphic Report (Printer)** to print a hard copy if needed. Also, tabular report can be viewed or printed.

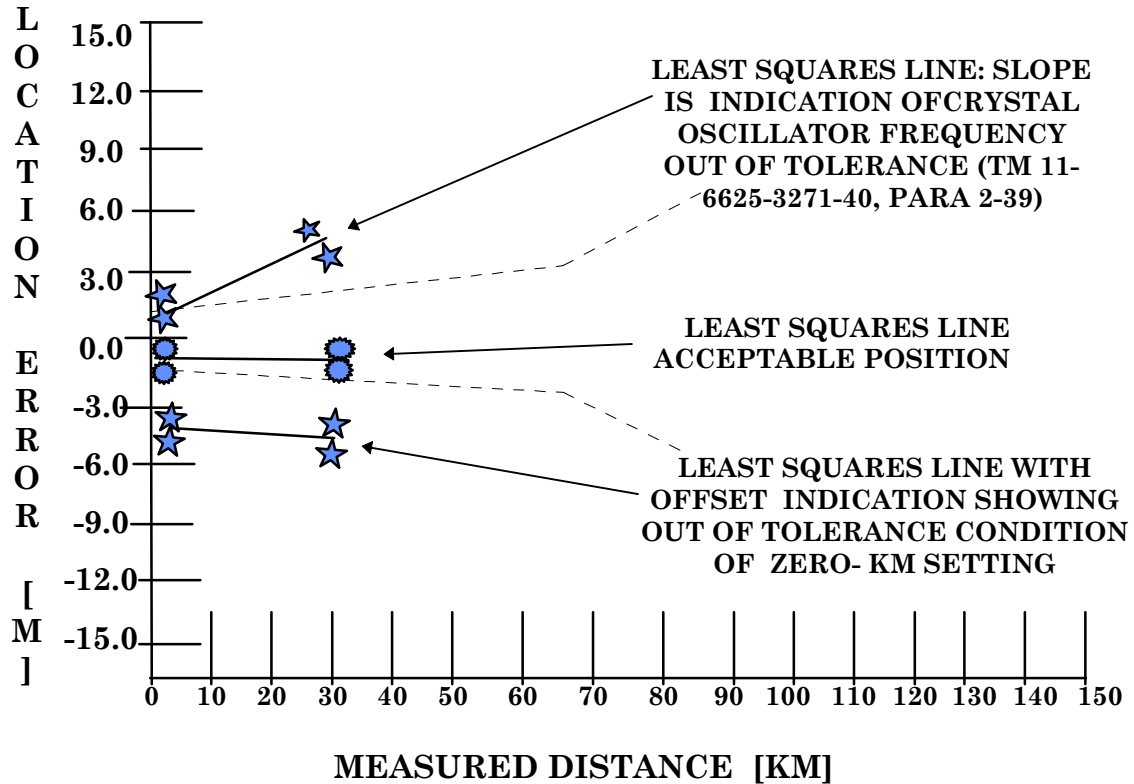

Insertion Delay [nanosec]	: 209	OFTS Horizontal Scale Calibration	
Index of Refraction	: 1.4990		
Wavelength [nm]	: 850	Model: TS-4320	Date: 12-9-94
Pulse width	: Short	Main Frame SN: 9305-0003	Optical Module SN: 9307-0119
Location Offset [m]	: -0.95		Model Name: TD-260C
Scale Deviation [m/km]	: -0.0128		
Maximum Readout error [m]	: 1.00		

Figure 7. Examples of graphic report (screen). 'Least squares line' between dashed boundary lines is acceptable. (Only one 'least squares line' will be displayed at a time.) Other 'least squares lines' are explained in **NOTE** below.

NOTE

Data for each TS-4320 OFTS optical module is divided into two sets or clusters – first cluster near origin and second near end of optical module horizontal scale rated dynamic range. TI measurement data is taken for each cluster until a shift is produced in pulse position. The last data point in cluster will be lowest actual error for that cluster. The data point immediately prior to the last data point is the highest error. Technique is same for second cluster. These four data points are used to plot a least squares line and calculate location offset, scale deviation, and maximum location readout error. Location offset is Y axis intercept of least squares line fitted to

data points. This is a close approximation of constant horizontal scale error due to TS-4320 OFTS timing circuitry not in sync with out going optical pulse as it passes through OFTS fiber connector. Absolute value of location offset should be less than or equal to 1.00 meter to be in tolerance. Scale deviation is slope of least squares line fitted to data points. This is a close approximation of relative error due to the OFTS timing circuitry (oscillator) either running too fast or too slow. A positive scale deviation value means oscillator frequency is too high while a negative value indicates it is too low. If slope of least squares line is extreme; i.e., the far end of least squares line is beyond dashed boundary lines, this condition is usually an indication of incorrect oscillator frequency on DAS 1A2A4 circuit card. If least squares line is beyond boundary lines but this is not due to extreme slope (above or below), this is an indication of ZERO-KM SETTING requiring adjustment. Location readout error is worst-case summation of both the OFTS data point sampling error and the calibrator cursor placement error on leading edge of FOCUS generated pulse. This is shown by spread of two data points in second cluster. This amount of random error is to be expected in normal operation at maximum range. (TD-260C will have a normal spread of 2 meters, TD-261C - 4 meters and TD-285C - 8 meters).

(20) If OFTS calibration software indicates out-of-tolerance condition for TI, perform **b** below.

b. Adjustments. Perform adjustments in Section IV and repeat paragraph 8.

9. Attenuation Scale Non-linearity

a. Performance Check

(1) Connect equipment as shown in figure 3, CONNECTION A. Connect ST END of OPTICAL FIBER JUMPER CABLE to LIGHTWAVE MULTIMETER OPTICAL INPUT and connect FC END to FOCUS-SWCM OPTICAL IO (fig. 3).

(2) Adjust **FOCUS-SWCM** controls as indicated in (a) through (c) below:

(a) Set **LD BIAS CURRENT** switch to **LD PULSED**.

(b) Set **SWITCHED ATTN** switch to **OUT**.

(c) Adjust **VAR ATTN 1** control for approximately -27 dBm optical power amplitude indication at 850 nm on lightwave multimeter and record indication.

NOTE

When calibrating TD-285C optical module, adjust **VAR ATTN 1** control for approximately -38 dBm at 1310 nm and 1550 nm.

(3) Set **FOCUS-SWCM SWITCHED ATTN** switch to **IN**.

(4) Adjust **FOCUS-SWCM VAR ATTN 2** control for an optical power amplitude indication on lightwave multimeter 6.0 dBm (± 0.5 dB) lower than recorded in (2)(c) above.

NOTE

This will produce a nominal 3 dB power level difference when displayed on TI. Take care not to disturb optical fiber jumper cable when making measurements or disconnecting fiber connectors. Excess optical fiber jumper cable length should be coiled in 6 inch (approximate) diameter loops and taped temporarily to bench top to avoid unnecessary movement of the cable.

(5) Lock **FOCUS-SWCM VAR ATTN 2** control using locking tab on control.

NOTE

Steps which follow test repeatability of switched attenuator. Referenced attenuation data sheet values will be averaged by OFTS calibration software.

(6) Set **FOCUS-SWCM SWITCHED ATTN** switch to **OUT** and record lightwave multimeter indication in Power High Ref column on TD-260C (850 nm) Reference Attenuation Data Sheet (appendix A).

(7) Set **FOCUS-SWCM SWITCHED ATTN** switch to **IN** and record lightwave multimeter indication in Power Low Ref column on TD-260C (850 nm) Reference Attenuation Data Sheet (appendix A).

(8) Repeat steps a(6) and (7) above recording lightwave multimeter indication for each remaining column (three total) on TD-260C (850 nm) Reference Attenuation Data Sheet.

(9) Set digital delay/pulse generator controls as indicated in (a) through (m) below:

(a) Press **MENU TRIG** pushbutton to cycle through steps (b) through (e) below.

(b) **TRIG** to **EXT**

(c) **THRESHOLD** to **+0.50 V**

NOTE

Some TI/FOCUS combinations will not produce proper external triggering of digital delay/pulse generator at a trigger threshold of +0.05 V. Reduction of trigger threshold in this case to obtain a good trigger is acceptable for attenuation scale non-linearity measurements only.

- (d) **SLOPE (+/-)** to +.
 - (e) **TRIGGER TERM** to **50 OHM**.
 - (f) Press **MENU OUTPUT** pushbutton to cycle through steps (g) through (k) below.
 - (g) **OUTPUT** to **AB**
 - (h) **AB & -AB LOADS** to **50 OHMS**
 - (i) **AB: VAR**
 - (j) **AB: AMPLITUDE** to **+2.00 V**
 - (k) **AB: OFFSET** to **-1.60 V**.
 - (l) Press **MENU DELAY** pushbutton to set **A Delay** to **A=T+ 0.000050000000** (50 μ sec).
 - (m) Press **MENU DELAY** pushbutton to set **B Delay** to **B=A+ 0.000010000000** (10 μ sec).
- (10) Carefully remove optical fiber jumper cable connection from lightwave multimeter OPTICAL INPUT (fig. 3) and connect to TI fiber connector.
- (11) Press **TI DISPLAY FROM** pushbutton to select **ORIGIN**.
 - (12) Use technique of 8a(2) above to set **TI NEW LEN/RES** to **8.0 km/0.5m**.
 - (13) Press **PULSE WIDTH** pushbutton to select **LONG**.
 - (14) Set **FOCUS-SWCM SWITCHED ATTN** switch to **OUT**.
 - (15) Press **REAL TIME** pushbutton.
 - (16) Adjust **FOCUS-SWCM VAR ATTN 1** control until **FOCUS** generated pulse has approximately same amplitude as *dead zone pulse* as displayed on TI (fig. 8).

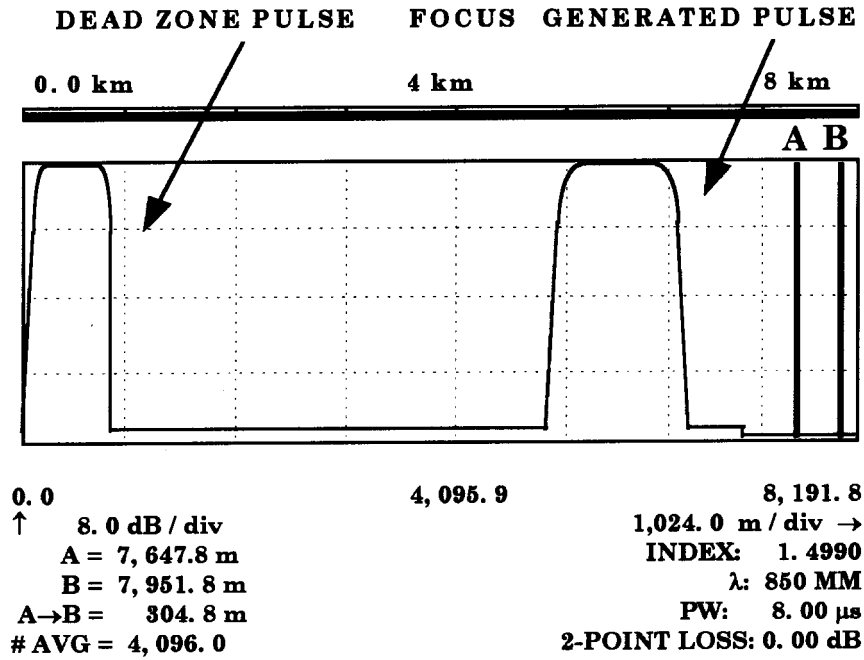

Figure 8. Example of FOCUS generated pulse equal to *dead zone pulse* amplitude (TD-260C).

(17) Press **HOR EXP** pushbutton to expand display to view *dead zone pulse* (fig. 9).

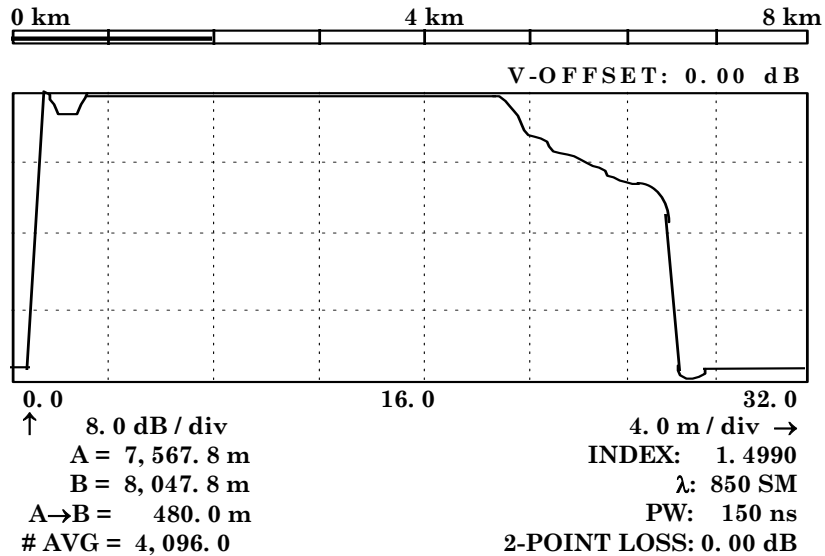

Figure 9. Example of expanded *dead zone pulse* - (TD-260C).

TB 9-6625-2309-35

(18) Adjust **CURSOR A** control to place cursor A on peak (or approximate middle if no peak is evident) of TI *dead zone pulse* (fig. 10) or peak of *dead zone pulse* if peak is evident (TD-260C and TD-261C optical modules) (fig. 11). Record **A=** distance indicated on TI display on appropriate Reference Cursor Position Data Sheet (appendix A).

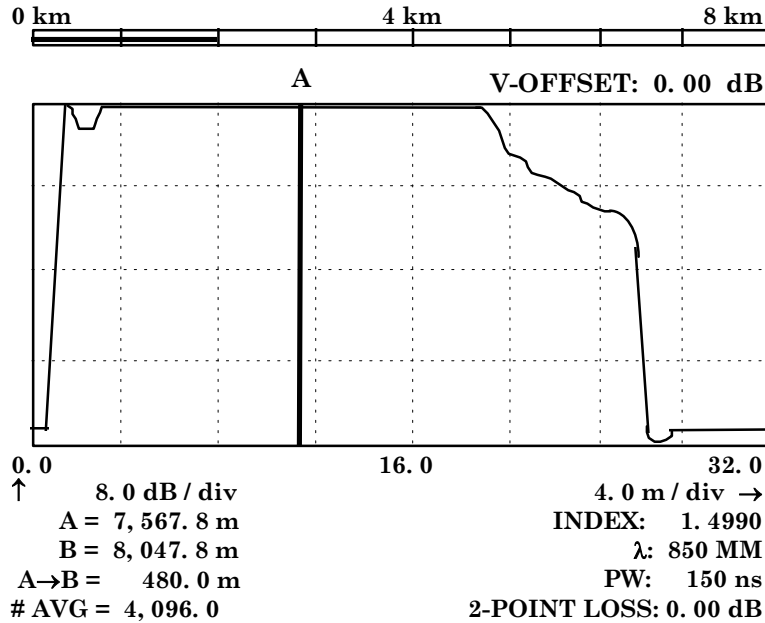

Figure 10. Example of cursor A on approximate middle of *dead zone pulse* with no peak evident (TD-260C shown for example).

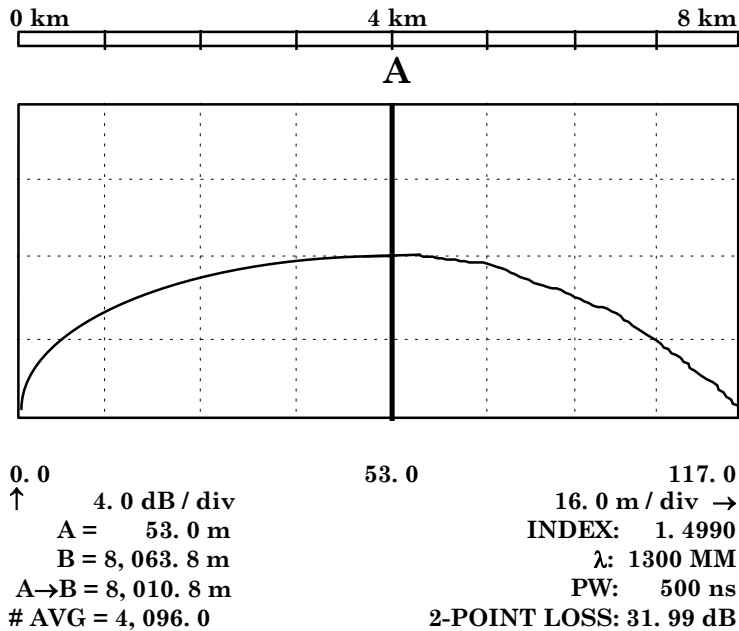

Figure 11. Example of cursor A on peak of *dead zone pulse*- (TD260C).

NOTE

Take care not to move **CURSOR A** control during measurements to reduce error. If **CURSOR A** control is moved, reposition cursor until TI displays **A =** recorded position again. Doing this will reestablish same optical power reference level as before and calibration may continue with no additional error.

(19) Press **HOR CONT** pushbutton for maximum horizontal contraction.

(20) Press **DISPLAY FROM** pushbutton to select **B**.

(21) Adjust **CURSOR B** control to place cursor B in approximate middle of flat portion on top of FOCUS generated pulse (fig. 12). Record **B=** distance indicated on TI display on TD-260C (850 nm) Reference Cursor Position Data Sheet (appendix A).

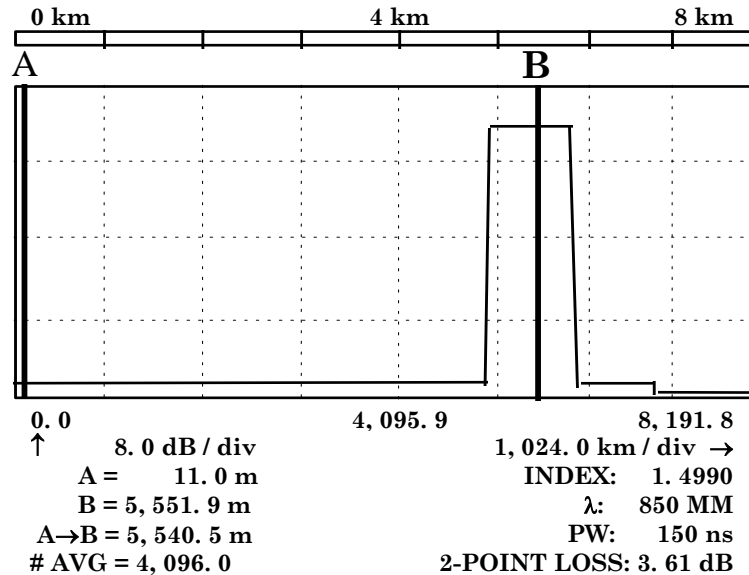

Figure 12. Example of cursor B placement in center flat portion on FOCUS generated pulse (TD-260C).

NOTE

Take care not to move **CURSOR B** control during measurements to reduce error. If **CURSOR B** control is moved, reposition cursor B so TI displays **B =** recorded reference cursor position again. This will reestablish same measured power level on FOCUS generated pulse as before and calibration may continue with no additional error.

(22) Perform (a) and (b) below:

(a) Press **TI LOSS MODE** pushbutton to select **2 POINT**.

NOTE

Ensure TI display indicates **2-Point Loss** and not **LSA/2 PT Loss**: If TI display indicates the latter, change by pressing second unmarked softkey from top.

(b) Press **REAL TIME** pushbutton, if necessary, to turn **LASER** on.

(23) Adjust **FOCUS-SWCM VAR ATTN 1** control for a 2-point loss indication on TI display of $+4.0 \pm 0.1$ dB.

(24) Press **FAST SCAN** pushbutton and wait for displayed **LASER ON/AVG** and **WORKING** indications to go off indicating completion of data acquisition.

(25) Record 2-point loss value displayed on TI in Power High column on TD-260C (850 nm) Attenuation Data Sheet (appendix A).

(26) Position **FOCUS-SWCM SWITCHED ATTN** switch to **IN**.

(27) Press TI **FAST SCAN** pushbutton and wait for **LASER ON/AVG** and **WORKING** on TI display to go off.

(28) Record 2-point loss value displayed on TI in Power Low column on TD-260C (850 nm) Attenuation Data Sheet (appendix A).

(29) Set **FOCUS-SWCM SWITCHED ATTN** switch to **OUT**.

(30) Press **REAL TIME** pushbutton.

(31) Adjust **FOCUS-SWCM VAR ATTN 1** control for a 2-point loss value on TI display of 0.2 dB less than last 'Power Low' value previously recorded on attenuation data sheet.

Example:

Last 'Power Low' level = 7.00 dB. Adjust 2-point loss to approximately 6.8 dB.

(32) Press **FAST SCAN** pushbutton and wait for **LASER ON/AVG** and **WORKING** on display to go off.

(33) Record 2-point loss value as next Power High column entry on TD-260C (850 nm) Attenuation Data Sheet.

(34) Set **FOCUS-SWCM SWITCHED ATTN** to **IN**.

(35) Press TI **FAST SCAN** pushbutton and wait for TI **LASER ON/AVG** and **WORKING** indications to go off.

(36) Record 2-point loss value as next entry in Power Low column on TD-260C (850 nm) Attenuation Data Sheet (appendix A).

(37) Repeat technique of steps a(29) through (36) until top of FOCUS generated pulse is within 8 dB of TI noise floor peak (fig. 13).

NOTE

Some spaces on attenuation data sheets may not be necessary due to optical module dynamic range differences.

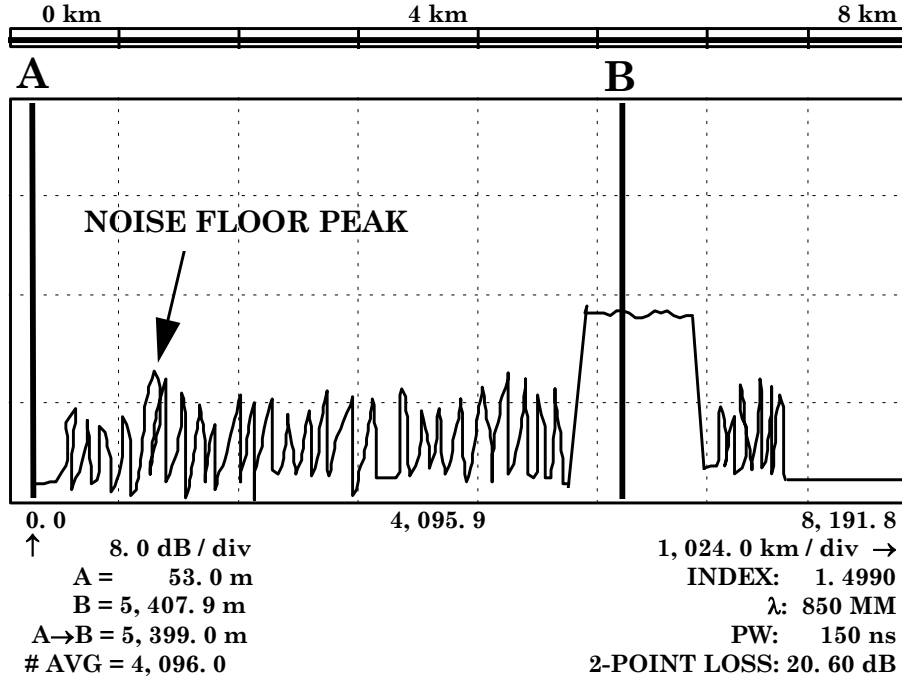

Figure 13. Top of FOCUS generated pulse within 8 dB of TI noise floor peak for fast scan (TD-260C).

(38) Load TS-4320 OFTS calibration software on an MS-DOS compatible PC according to instructions in Calibration Software User's Manual.

(39) Press **2** on keyboard to access TS-4320 OFTS **Attenuation Scale Calibration Menu** and enter requested user input information.

(40) Perform steps (a) through (e) below:

(a) Press **1** on keyboard to access Enter Reference Attenuation Data page.

(b) From selected TI optical module data sheet, type in data from Power High Ref (dBm) column and press **ENTER**.

TB 9-6625-2309-35

(c) From selected TI optical module data sheet, type in data from Power Low Ref (dBm) column and press **ENTER**.

(d) Repeat technique of (b) and (c) above as necessary to enter remaining data from data sheet.

(e) When all data has been entered press **Esc**.

(41) Perform steps (a) through (i) below:

(a) Press **2** on key board to access Enter/Edit Attenuation Measurement Data.

(b) Press **I** on keyboard to insert data.

(c) At prompt, **Enter power high (dBm):**, type in data from Power High column on selected TI optical module data sheet (appendix A).

(d) At prompt, **Enter power low (dBm):**, type in data from Power Low data column on selected TI optical module data sheet (appendix A).

(e) Repeat technique of steps (b) through (d) above as necessary for remaining data on TI optical module data sheet.

(f) Verify data has been entered correctly.

(g) Press **S** on keyboard at prompt and enter **B** = reference cursor position in km.

(h) Press **Q** on keyboard to quit data edit page.

(i) **OFTS Attenuation Scale Calibration** menu will appear on screen.

(42) Perform steps (a) through (c) below:

(a) Press **3** on keyboard to select **Generate Report**.

(b) **Generate Attenuation Report** menu will appear on screen.

(c) Press **2** on keyboard to select **Graphic Report (Screen)** then press **1** on keyboard to select **Graphic Report (Printer)** to print a hard copy to be sent to customer. Refer to note immediately following figure 14 for pass/fail condition.

NOTE

Boundaries shown on graphical report are normal nonlinearity limits for TI (fig. 14).

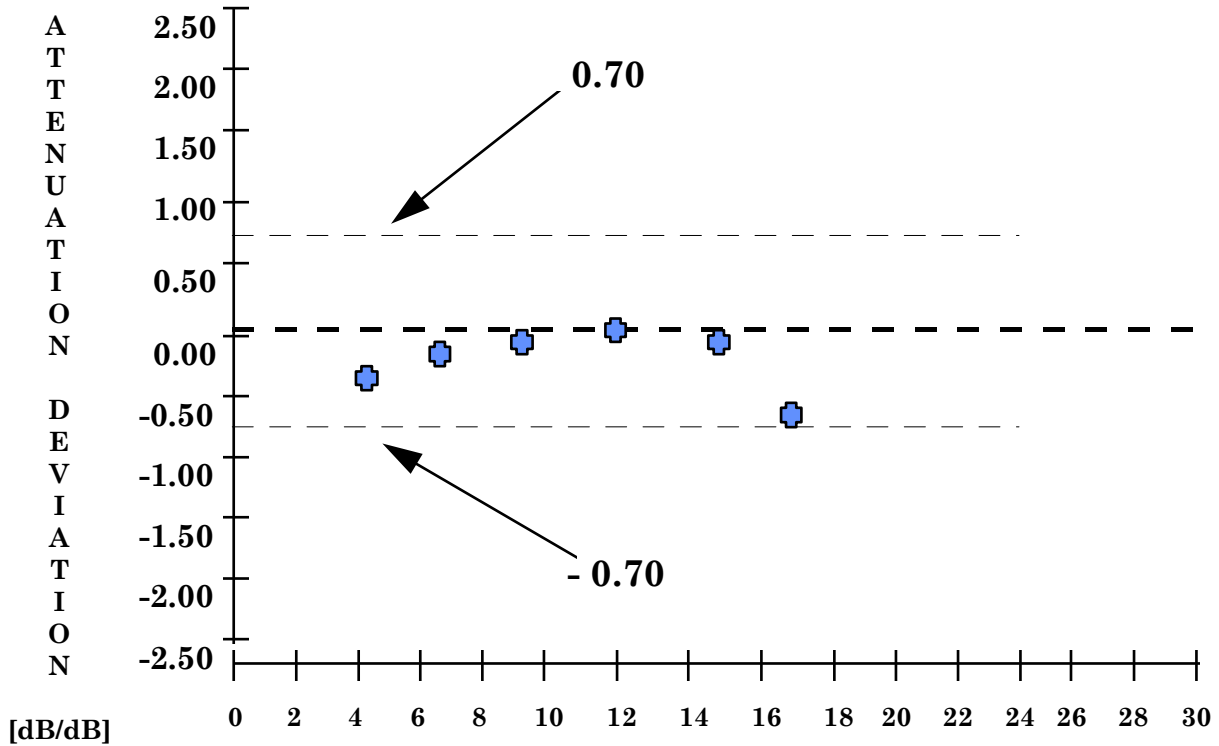

“POWER HI” ATTENUATION LEVEL WITH RESPECT TO CLIPPING LEVEL (=0 DB)

Distance [km]	: 0.00		
Reference Attenuation [dB]	: 3.04	OFTS Distance Scale	
		Calibration	
Pulse Width	: long		
Wavelength [nm]	: 850	Model: TS-4320	Date: 8-30-94
		Main Frame SN: 935-003	Optical Module SN: 112-385

Figure 14. Reference attenuation graphic.

NOTE

If any attenuation deviation data points are outside of non-linearity boundaries (dashed lines near 0.70 and -0.70), TI requires adjustment or repair. Verify measurements and data, then perform **9b** below.

NOTE

If tabular report is desired, use technique of (42)(c) above for option desired.

(43) Repeat technique of **7I** above and set Index of Refraction to Customer Existing value recorded on data sheet.

(44) Set **TI ON-OFF** switch to **OFF**.

CAUTION

DO NOT remove optical modules with power on or damage to optical module may occur.

(45) Remove TD-260C optical module and install TD-261C optical module in **TI**.

(46) Remove FOCUS-SWCM from test setup and install FOCUS-LWCM (fig. 3)

(47) Set **FOCUS-LWCM WAVELENGTH** switch to **1300 nm**.

NOTE

FOCUS-LWCM nominal wavelength is actually 1310 nm when **WAVELENGTH** switch is set to **1300 nm**. **WAVELENGTH** switch nomenclature was changed during manufacture of this test equipment. Slight wavelength difference between **TI** and **FOCUS** produces negligible effect on measurements.

(48) Set lightwave multimeter to measure optical power in dBm at 1300 nm.

(49) Set **ON-OFF** switch to **ON**.

(50) Repeat technique of paragraph **7b** through **7I**, and paragraphs **8**, and **9** above for TD-261C optical module.

(51) Repeat technique of **7I** above and set Index of Refraction to Customer Existing value recorded on data sheet.

(52) Set **ON-OFF** switch to **OFF**.

(53) Remove TD-261C optical module and install TD-285C optical module in **TI**.

(54) Set **ON-OFF** switch to **ON**.

(55) Set **TI** wavelength to 1310 nm as required by pressing softkey next to **λ:** on **TI** display.

(56) Set lightwave multimeter to measure optical power in dBm at 1310 nm.

(57) Repeat technique of paragraph **7b** through **7l**, and paragraphs **8** and **9** above for TD-285C optical module at 1310 nm.

NOTE

TD-285C optical module label reads 1300/1550 nm. Actual 1300 nm wavelength is 1310 nm.

(58) Set **FOCUS-LWCM WAVELENGTH** switch to **1550 nm**.

(59) Set TI wavelength to 1550 nm as required by pressing softkey next to λ : on TI display.

(60) Set lightwave multimeter to measure optical power in dBm at 1550 nm.

(61) Repeat technique of paragraph **7b** through **7l**, and paragraphs **8** and **9** above for TD-285C optical module at 1550 nm.

(62) Repeat technique of **7l** above and set Index of Refraction to Customer Existing value recorded on data sheet.

b. Adjustments. Perform adjustments in Section IV and repeat paragraph **9**.

**SECTION IV
CIRCUIT ALIGNMENT**

10. A/D Adjustments

WARNING

HIGH VOLTAGE is used during performance of this calibration. DEATH ON CONTACT may result if personnel fail to observe safety precautions. REDUCE OUTPUT(S) to minimum after each step within the performance check where applicable.

CAUTION

Use ESD precautionary procedures when touching, removing or installing circuit card assemblies.

NOTE

A/D adjustments in this paragraph are performed to ensure mainframe of TI is within nominal parameters.

a. Perform (1) through (5) below:

TB 9-6625-2309-35

- (1) Set **ON-OFF** switch to **OFF**.
- (2) Remove TI top cover.
- (3) Connect frequency counter probe ground to **GROUND BRAID A/D 1A2A8** (fig. 15).

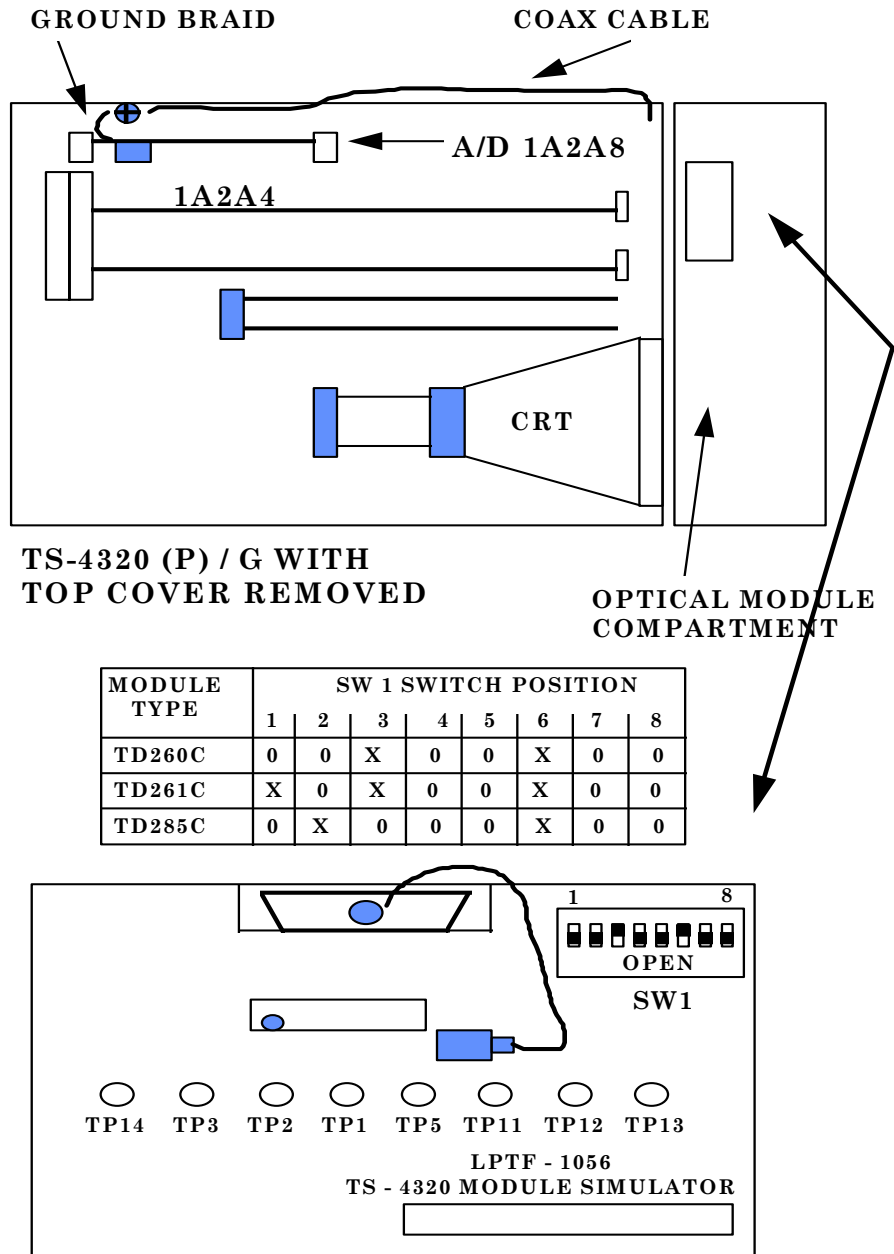

Figure 15. TS-4320(P)/G board locations and optical module simulator.

- (4) Set **ON-OFF** switch to **ON**.

NOTE

Allow 15 minutes for TI to warm-up before making voltage measurements.

- (5) Place frequency counter probe tip on solder side of DAS 1A2A4 circuit board at IC U71, pin 9 (fig. 16). Frequency will be between 24.99925 to 25.00075 MHz; if not, repair is indicated.

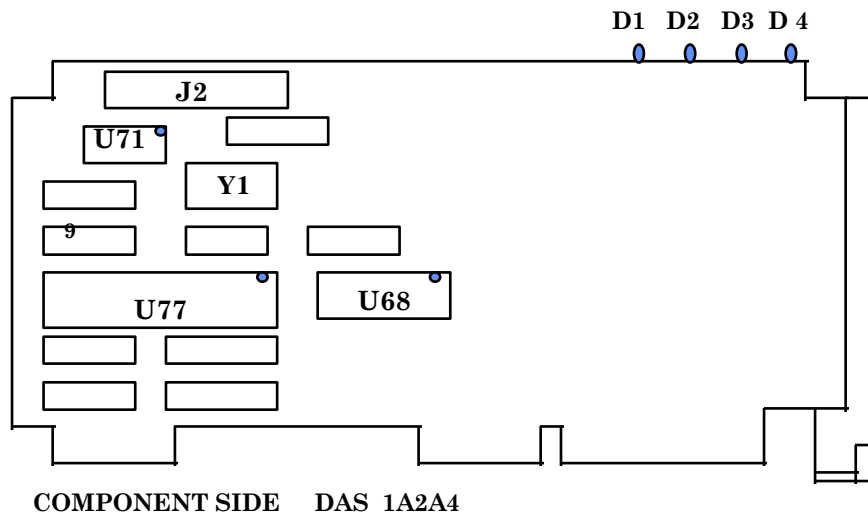

Figure 16. U71 location on DAS 1A2A4 circuit board.

- b.** Perform (1) through (9) below:

- (1) Set **ON-OFF** switch to **OFF**.
- (2) Remove chassis screw anchoring GROUND BRAID at A/D 1A2A8 circuit board (fig. 15).
- (3) Remove electrical tie down straps if present.

CAUTION

Twisting coax connector or stretching may damage coax. Pull straight back and or use flat blade screwdriver to pry coax connector loose.

- (4) Remove coax connector from J1 (fig. 17).
- (5) Remove A/D 1A2A8 circuit board (fig. 15).

TB 9-6625-2309-35

- (6) Install A/D SHORTING PLUG (LPTF-1047) on J1 (fig. 17).

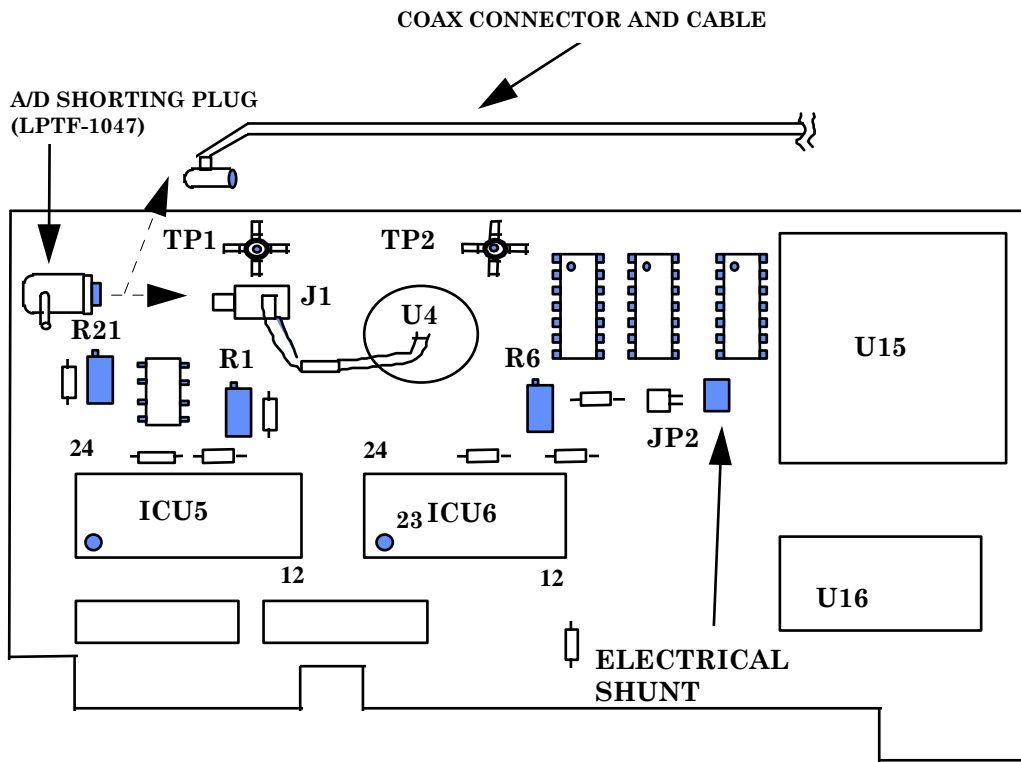

Figure 17. A/D 1A2A8 - adjustment locations.

- (7) Install A/D extender card (LPTF-1048) into TI A/D 1A2A8 mother board connector.
- (8) Install A/D 1A2A8 circuit board on extender card.
- (9) Connect GROUNDING BRAID (fig. 15) to TI chassis using jumper wire.

NOTE

Allow 15 minutes for TI to warm-up before making voltage measurements.

- c. Set **ON-OFF** switch to **ON**.
- d. Connect multimeter negative lead to ICU6, pin 12, and positive lead to ICU6, pin 23 (fig. 17).

NOTE

Multimeter negative lead may be connected to shield of TP1 (fig. 17) on A/D 1A2A8.

- e. Record multimeter indication (multimeter indication should be near -2.00 V dc).
- f. Move multimeter positive lead to ICU5, pin 24 (fig. 17).
- g. Multimeter will indicate positive within ± 0.05 V dc of recorded value in e above; if not, adjust R6 (fig. 17) R).
- h. Repeat technique of d through g above for a multimeter indication within ± 0.05 V dc.
- i. Connect multimeter negative lead to ICU6, pin 12 and positive lead to ICU5, pin 23 (fig. 17). Multimeter will indicate between +9 and +11 mV dc; if not, adjust R1 (fig. 17) (R).
- j. Perform (1) through (7) below:
 - (1) Set **ON-OFF** switch to **OFF**.
 - (2) Disconnect multimeter leads.
 - (3) Install electrical shunt across JP2 (fig. 17).

NOTE

Electrical shunt is currently on one of two pins on JP2 (fig. 17).

- (4) Remove A/D SHORTING PLUG (LPTF-1047) from J1 (fig. 17).

NOTE

Tie down strap on TI inside chassis wall may need to be cut to allow more coax movement (observe caution).

- (5) Install coax connector on J1 (A/D 1A2A8) (fig. 17) circuit board (observe caution).
- (6) Remove existing optical module from TI.
- (7) Install LPTF-1056 (TS-4320) MODULE SIMULATOR in TI OPTICAL MODULE COMPARTMENT (fig. 15).

NOTE

Ensure module switch positions on module simulator board are set to any one of the three optical modules.

TB 9-6625-2309-35

- k. Set **ON-OFF** switch to **ON**.

NOTE

Allow 15 minutes for TI to warm-up before making voltage measurements.

- l. Connect multimeter negative lead to ICU6, pin 12 and positive lead to TP2 center post on A/D 1A2A8 circuit board (suggest making connections on solder side of A/D 1A2A8 (fig. 17)).

- m. Multimeter will indicate between 1.700 and 1.650 V dc, if not adjust R21 (fig. 17) (R).

- n. Perform (1) through (11) below:

- (1) Set **ON-OFF** switch to **OFF**.

- (2) Remove multimeter connections.

- (3) Remove jumper wire connection from TI chassis and A/D 1A2A8 GROUNDING BRAID (fig. 15).

- (4) Remove electrical shunt from connector on A/D 1A2A8 circuit board JP2 (fig. 16) and install electrical shunt to a single pin on JP2.

- (5) Remove A/D 1A2A8 circuit board from extender card (LPFT-1048).

- (6) Remove extender card (LPTF-1048) from TI.

- (7) Reinstall A/D 1A2A8 circuit board in TI.

- (8) Reinstall A/D 1A2A8 circuit board GROUNDING BRAID (fig. 15) to chassis.

- (9) Remove MODULE SIMULATOR from TI OPTICAL MODULE COMPARTMENT (fig. 15).

- (10) Replace TI top cover assembly.

- (11) Reinstall optical module into TI optical module compartment.

11. Installation and Use of Software Level 1.08a

NOTE

The following steps install software level 1.08a into system software of TI. This software is used to alter start time, in nanoseconds, of data collect cycle, causing TI optical trace to move left or right on crt. This will cause change to distance reading.

NOTE

When software level 1.08a is used to change distance parameters (**ZERO-KM SETTING**) of an optical module for a given wavelength, that particular optical module must remain with TI mainframe for calibration to remain valid.

CAUTION

Never connect/disconnect keyboard or external disk drive to TI with power on or damage may occur to TI.

- a. Perform setup steps (1) through (4) below:
 - (1) Place TI **ON/OFF** switch to **OFF**.
 - (2) Connect keyboard cable to **KEY BD** connector located on rear of TI.
 - (3) Connect external disk drive cable to **EXT.DSK** connector located on rear of TI.
 - (4) Place TI **ON/OFF** switch to **ON**.
- b. To install software level 1.08a, perform steps (1) through (22) below:
 - (1) Place 720K 3.5 inch floppy disk containing files in external disk drive.

NOTE

TI external drive has 720K format and can only read or write to a 3.5 inch 720K floppy disk.

- (2) At TI display crt screen **Press Any Main Panel Key To Begin**, press any main panel key.
- (3) Press **HELP** pushbutton.
- (4) Press **MORE** softkey.
- (5) Press **STORAGE MAINT.** softkey.
- (6) Press **CHANGE DRIVE** softkey.
- (7) Press **DEFAULT Drive A** softkey.
- (8) Press **MORE** softkey.
- (9) Press **STORAGE MAINT.** softkey.
- (10) Press **COPY FILES** softkey.

TB 9-6625-2309-35

- (11) Adjust **CURSORS A** control to highlight filename **OTDRCODE.EXE 03/13/95**.
- (12) Press **SELECT FILE** softkey.
- (13) Adjust **CURSORS A** control to highlight filename **OTSFTXTC.DAT 03/13/95**.
- (14) Press **SELECT FILE** softkey.
- (15) Press **COPY SELECTIONS** softkey.
- (16) Press **C:** key on keyboard.

NOTE

CURSORS A & B knobs can be used to enter drive letter. Keyboard is needed for a warm boot of TI to maintain correct sync established in Section III, paragraph **7b**.

- (17) Ensure **C:** appears just below **Copy Selected File(S) to:** on TI display.
- (18) Press **START COPY** softkey.
- (19) Wait for message **Copying in Progress PLEASE WAIT** to disappear from TI display.
- (20) Remove floppy disk from external drive.
- (21) On keyboard simultaneously press keys **Ctrl, Alt, Del** to warm boot TI.
- (22) After warm boot of TI, **Software Level 1.08a** should appear when **Press Any Main Panel Key To Begin** screen is displayed.

NOTE

Steps in **c** below are used to move optical trace to left or right causing a change in distance scale reading.

NOTE

If steps in **c** below are used to change ZERO-KM SETTING to a value other than **0**, the ZERO-KM SETTING must be returned to **0** for steps in Section III, paragraph **7a** and **b** to be valid. Record value of ZERO-KM SETTING and restore this value after performing steps in Section III, paragraph **7a** and **b**.

- c.** To change ZERO-KM SETTING perform steps (1) through (10) below:

- (1) If **Press Any Main Panel Key To Begin** screen is displayed press any key, then press **HELP** pushbutton or press **HELP** pushbutton if distance scale is displayed on crt.

- (2) Press **MORE** softkey.
- (3) Press **INSTRUMENT SETUP** softkey.
- (4) Press **OTDR SETUP** softkey.
- (5) Press **GPIB ADDR/MODE** softkey.
- (6) Adjust **CURSORS B** control to display **Adjust Zero-KM**.
- (7) Press **Adjust Zero KM** softkey.
- (8) Adjust **CURSORS A** control to display desired value (R).

NOTE

A positive number causes trace to move left on display (smaller measured distances). A negative number causes trace to move right on display. ZERO-KM SETTING value is displayed in nanoseconds; 1 nanosecond \cong 0.1 meters. Example: location off-set for an out-of-tolerance TI is -1.50m on graphic report, adjusting ZERO-KM SETTING approximately -15 nanoseconds will be needed to place TI in tolerance.

NOTE

Changing ZERO-KM SETTING only has effect on performance of presently installed optical module and wavelength which is selected. Optical module which has ZERO-KM SETTING other than **0** must remain with TI mainframe for calibration to remain valid.

- (9) Press **ACCEPT CHANGES** softkey.
- (10) To warm boot TI, on keyboard simultaneously press keys **Ctrl, Alt, Del**.

NOTE

Rebooting TI is necessary for ZERO-KM SETTING to take effect. Warm boot of TI is necessary to maintain proper sync established by SECTION III, paragraph **7b**.

NOTE

Perform steps in paragraph **12** below only if FOCUS SWCM or FOCUS LWCM standards have had optical subassembly repaired/replaced or DG535, digital delay generator, has been repaired/replaced.

12. Time Insertion Delay Characterization

NOTE

Steps which follow assume TD-260 optical module is presently installed in TI. Technique of paragraph 12 also applies to TD-261C and TD-285C optical modules. If removal of optical module is required, the steps in paragraph 7a and b must be performed to ensure proper sync.

- a. Connect equipment as shown in figure 18.

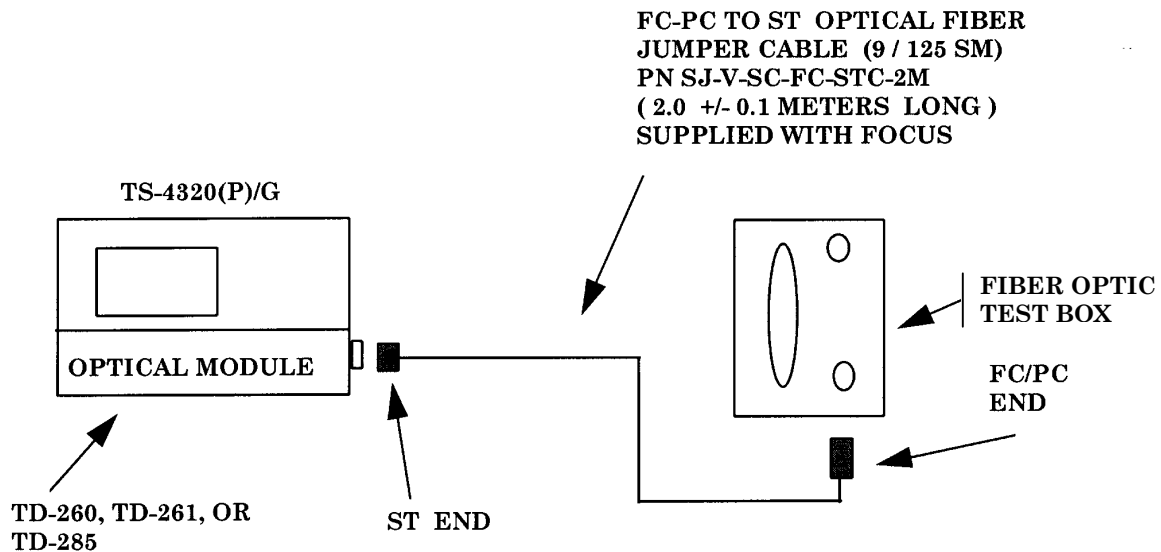

Figure 18. Equipment setup with fiber optic test box used to establish reference cursor position.

- b. To change length and resolution perform steps (1) through (8) below:
- (1) Press TI **HELP** pushbutton as required to change to **Help Facility** screen.
 - (2) Press **MORE** softkey.
 - (3) Press **INSTRUMENT SETUP** softkey.
 - (4) Press **OTDR SETUP** softkey.
 - (5) Press **FIBER LEN/RES** softkey.
 - (6) Adjust **CURSOR A** control to set new length to 8 km and resolution to 0.5 m.

- (7) Press **ACCEPT CHANGES** softkey.
- (8) Press **Return to OTDR Mode** softkey.
- c. To establish reference cursor position value perform steps (1) through (9) below:
 - (1) Press **PULSE WIDTH** pushbutton as required to select **SHORT**.
 - (2) Ensure **INDEX** is set to **1.4990**.

NOTE

To change index value, press and hold **N/LASER** pushbutton and adjust **CURSOR A** control to set **INDEX** to new value.

- (3) Press **DISPLAY FROM** pushbutton as required to select **ORIGIN**.
- (4) Press **FAST SCAN** pushbutton and wait for **LASER ON/AVG** to indication on TI display to go off.

NOTE

It may be necessary to press **HOR CONT** or **HOR EXP** pushbuttons in order to view **REFLECTIVE EVENT** (fig. 19).

- (5) Adjust **CURSOR A** control to place cursor A at leading edge of **REFLECTIVE EVENT** (fig. 19).

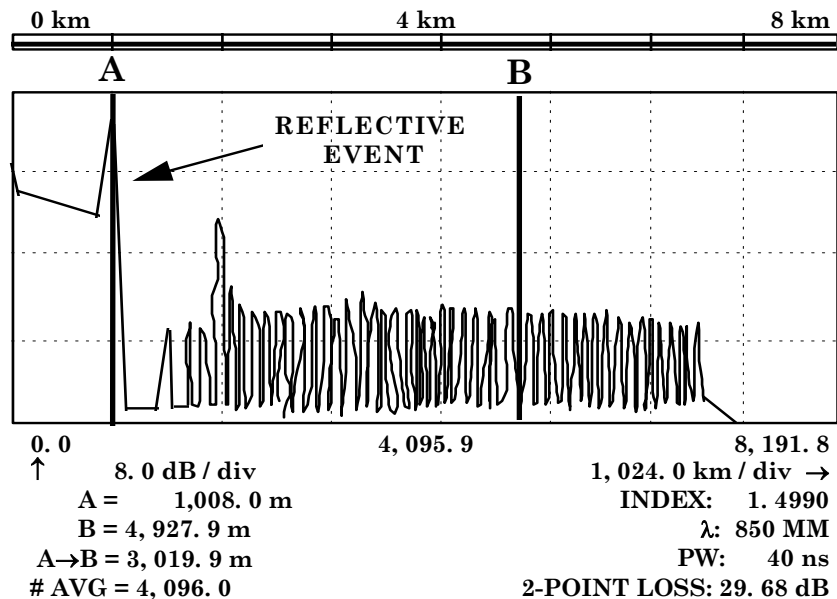

Figure 19. Course placement of cursor A after completing fast scan (TD-260C).

TB 9-6625-2309-35

- (6) Press **DISPLAY FROM** pushbutton as required to select **A**.
- (7) Press **HOR EXP** pushbutton as required to display **4.0 m/div** on crt.
- (8) Adjust **CURSOR A** control to carefully adjust cursor A to beginning of reflective event as shown in figure 20.

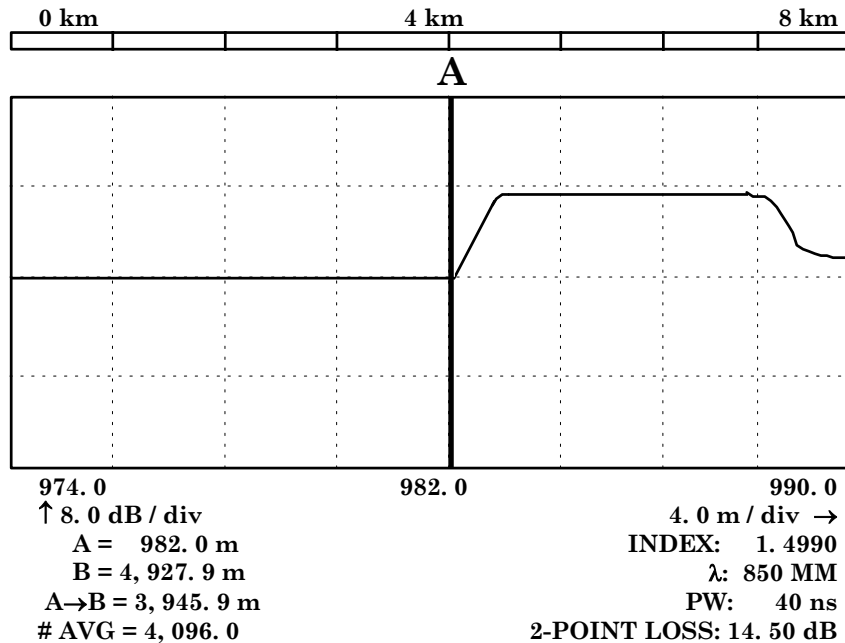

Figure 20. Placement of cursor A to get reference position (TD-260C).

- (9) Record A= distance in meters displayed on crt.

NOTE

Take care not to move cursor A from this reference position. If cursor A is moved, reference position must be reestablished.

- d. Remove fiber test box from test setup and connect equipment as shown in CONNECTION A (fig. 21) below.

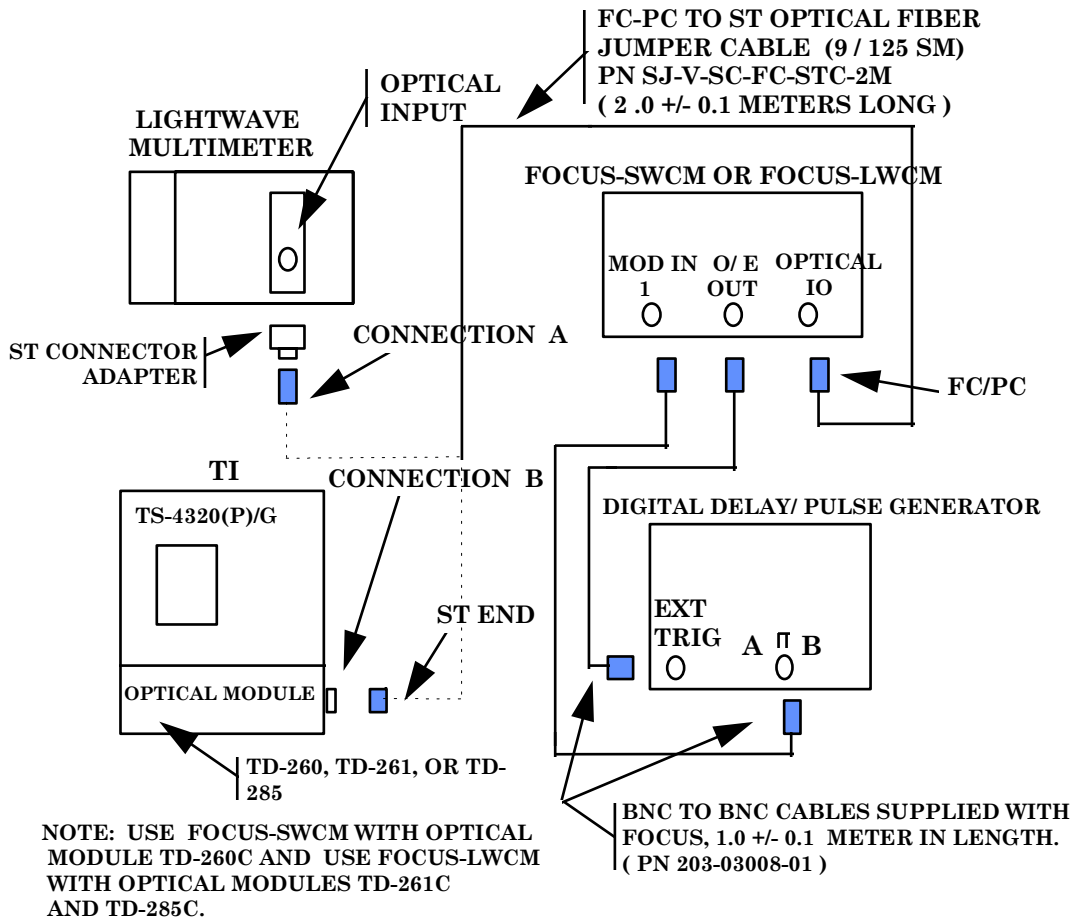

Figure 21. Equipment setup for time insertion delay after fiber test box is removed.

- e. Perform steps (1) through (7) below:
 - (1) Ensure **FOCUS-SWCM POWER OFF ON** key control switch is set to **ON**.
 - (2) Ensure digital delay/pulse generator **POWER ON-OFF** pushbutton is set to **ON**.
 - (3) Ensure lightwave multimeter power pushbutton is set to **ON**.
 - (4) Allow 15 minutes for test equipment to warm-up and stabilize.
 - (5) Set lightwave multimeter to measure optical power in dBm at 850 nm wavelength or nominal wavelength to be tested.

TB 9-6625-2309-35

(6) Set **FOCUS-SWCM LD BIAS CURRENT** switch to **LD PULSED**.

(7) Set **FOCUS-SWCM SWITCHED ATTN** switch to **OUT**.

f. Monitor lightwave multimeter and adjust **FOCUS-SWCM VAR ATTN 1** control for -27 ± 0.2 dBm optical power output.

NOTE

When calibrating TD-285C optical module, adjust FOCUS-LWCM VAR ATTN 1 for -38 ± 0.2 dBm at 1310 nm and 1550 nm.

g. Carefully remove optical fiber jumper cable connector from lightwave multimeter and connect to fiber connector of TD-260C optical module (located on right-hand side under black rubber dust boot) (CONNECTION B, figure 3).

h. Set digital delay/pulse generator controls to settings as indicated in (1) through (13) below:

NOTE

Digital delay/pulse generator softkeys have more than one function depending on mode of operation.

(1) Press **MENU TRIG** pushbutton to cycle through steps (2) through (5) below.

(2) **TRIG** to **EXT**.

(3) **THRESHOLDS** to **+0.50V**.

(4) **SLOPE (+/-)** to **+**.

(5) **TRIGGER TERM** to **50 OHM**.

(6) Press **MENU OUTPUT** to cycle through steps (7) through (11) below.

(7) **OUTPUT** to **AB**.

(8) **AB & -AB LOADS** to **50 OHM**.

(9) **AB:** to **VAR**.

(10) **AB: AMPLITUDE** to **+2.00V**.

(11) **AB: OFFSET** to **-1.60V**.

(12) Press **MENU DELAY** pushbutton to set **A Delay** to **A = T + 0.000010000000** (10 μ sec).

(13) Press **MENU DELAY** pushbutton to set **B Delay** to $B = A + 0.000010000000$ (10 μsec).

i. Press **REAL TIME** pushbutton.

j. Press **HOR CONT** as required to observe FOCUS generated pulse on TI display shown in figure 22 (do not move cursor A).

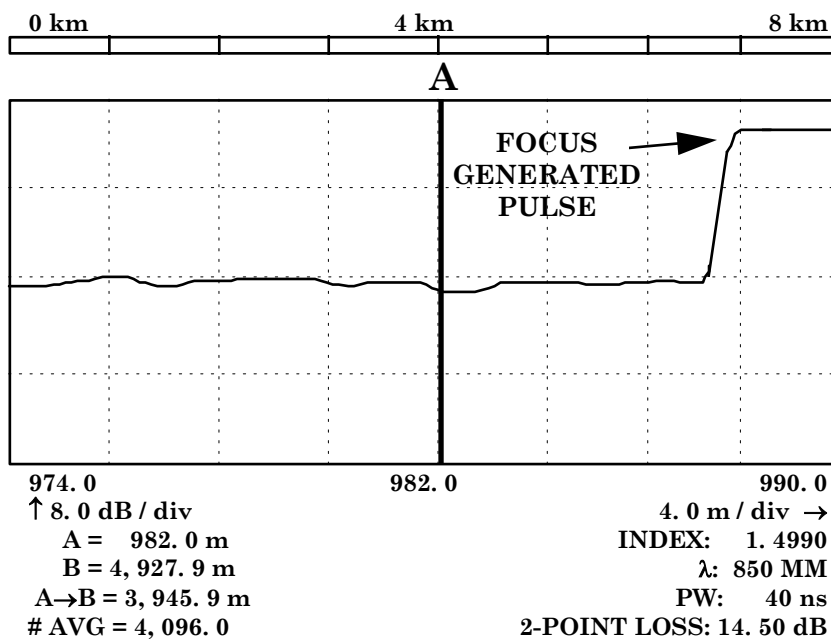

Figure 22. Example of locating FOCUS generated pulse (TD-260C).

k. Perform steps (1) through (4) below:

(1) Press digital delay generator **MENU DELAY** pushbutton to decrease $A = T+$ value by 100 nanoseconds increments until FOCUS generated pulse is just to the right of cursor A (fig. 23).

(2) Press **HOR EXP** as required for a display indication of **2.0m/div**.

(3) Repeat technique of (1) above using 10 nanosecond increments instead of 100 nanosecond increments (fig. 23).

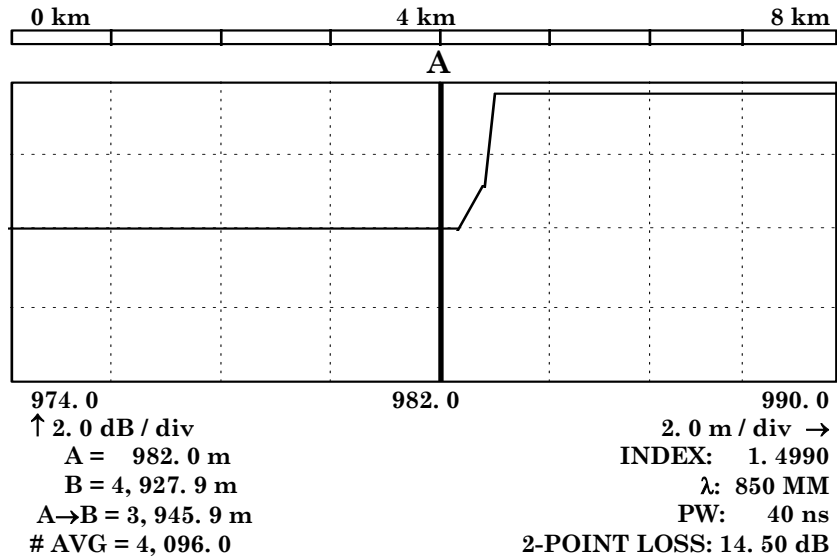

Figure 23. Example of FOCUS generated pulse placement just to right of cursor A before starting 3 nanosecond increments (TD-260C).

- (4) Press **VERT EXP** as required for a display indication of **2.0 dB/div**.

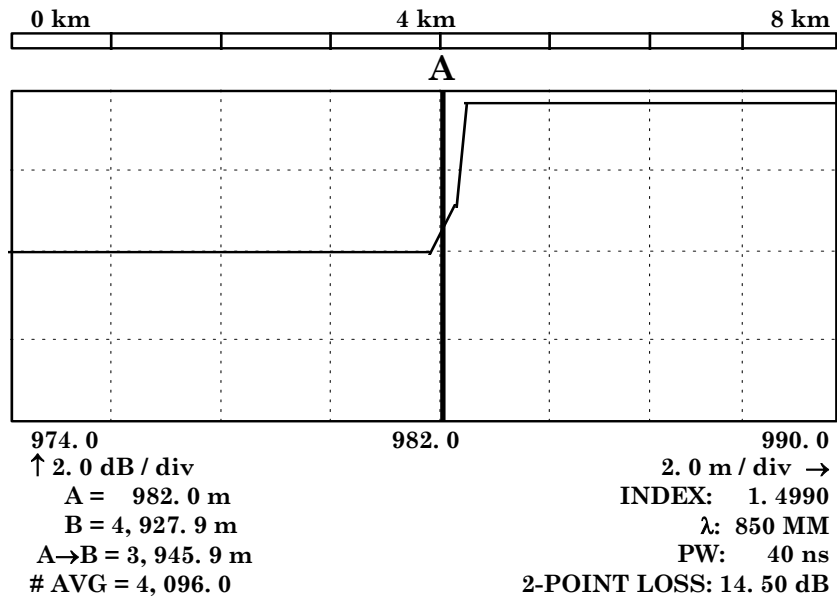

Figure 24. Example of FOCUS generated pulse placement to left of cursor A before starting 1 nanosecond increments (TD-260C).

l. To find lowest A = T+ value for FOCUS generated pulse at cursor A, perform steps (1) through (6) below:

(1) Press **FAST SCAN** pushbutton, wait for **LASER ON/AVG** to go off display.

(2) Press digital delay generator **MENU DELAY** pushbutton to decrease A = T+ in 3 nanosecond increments.

(3) Repeat technique of (1) and (2) above until beginning of FOCUS generated pulse shifts to left just in front of cursor A (fig. 24).

(4) Press digital delay generator **MENU DELAY** pushbutton to increase A = T+ by 1 nanosecond.

(5) Press **FAST SCAN** pushbutton and wait for **LASER ON/AVG** to go off display.

(6) Repeat technique of (4) and (5) above until very beginning of FOCUS generated pulse is on cursor A, figure 25. (Digital delay generator A = T+ value will be lowest value to obtain this condition).

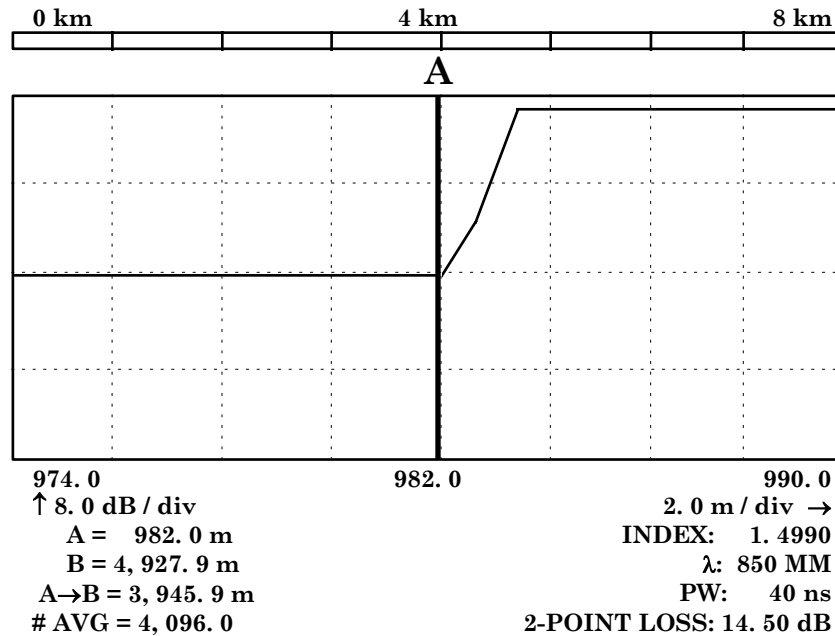

Figure 25. Example of FOCUS generated pulse placed in best possible position with respect to cursor A (TD-260C).

m. Record this: A = T+ value in nanoseconds (ns) and use this A = T+ value as “Equivalent Delay” in calculations below.

TB 9-6625-2309-35

- n. Compute calculations below:

$$T_{ID} = 2 (TOF) - EQUIVALENT DELAY + 2.5 \text{ ns}$$

NOTE

T_{ID} = Time insertion delay in ns for a given FOCUS unit/wavelength

TOF = Time of Flight in ns of Fiber Optic Test Box and 2 meter fiber optic jumper cable for a given wavelength from test report

EQUIVAL DELAY = A = T+ value recorded from **m** above

2.5 ns = Correction factor to minimize data point sampling error in this procedure

13. Final Procedure

- a. Deenergize and disconnect all equipment.
- b. Annotate and affix DA label/form in accordance with TB 750-25.

APPENDIX A
TD-260C (850 nm)
HORIZONTAL SCALE DATA SHEET

Digital Delay/ Pulse Generator Settings	Test Instrument	
	Indications	Settings
A = T + (μ s) (Cluster 1)	A= (km)	LEN/RES (km / m)
10.000		8.0 / 0.5
10.001		8.0 / 0.5
10.002		8.0 / 0.5
10.003		8.0 / 0.5
10.004		8.0 / 0.5
10.005		8.0 / 0.5
10.006		8.0 / 0.5
A = T + (μ s) (Cluster 2)		
300.000		32.0 / 2.0
300.005		32.0 / 2.0
300.010		32.0 / 2.0
300.015		32.0 / 2.0
300.020		32.0 / 2.0
300.025		32.0 / 2.0
300.030		32.0 / 2.0
300.035		32.0 / 2.0
300.040		32.0 / 2.0
Customer Existing Index of Refraction: _____		
Main Frame Serial number: _____		
Optical Module Serial number: _____		

APPENDIX A

**TD-261C (1300 nm)
HORIZONTAL SCALE DATA SHEET**

Digital Delay/ Pulse Generator Settings	Test Instrument	
	Indications	Settings
A = T + (μ s) (Cluster 1)	A= (km)	LEN/RES (km / m)
10.000		8.0 / 0.5
10.001		8.0 / 0.5
10.002		8.0 / 0.5
10.003		8.0 / 0.5
10.004		8.0 / 0.5
10.005		8.0 / 0.5
10.006		8.0 / 0.5
A = T + (μ s) (Cluster 2)		
600.000		64 / 4.0
600.005		64 / 4.0
600.010		64 / 4.0
600.015		64 / 4.0
600.020		64 / 4.0
600.025		64 / 4.0
600.030		64 / 4.0
600.035		64 / 4.0
600.040		64 / 4.0
Customer Existing Index of Refraction: _____		
Main Frame Serial number: _____		
Optical Module Serial number: _____		

APPENDIX A

**TD-285C (1310 nm)
HORIZONTAL SCALE DATA SHEET**

Digital Delay/ Pulse Generator Settings	Test Instrument	
	Indications	Settings
A = T + (μs) (Cluster 1)	A= (km)	LEN/RES (km / m)
20.000		8.0 / 0.5
20.001		8.0 / 0.5
20.002		8.0 / 0.5
20.003		8.0 / 0.5
20.004		8.0 / 0.5
20.005		8.0 / 0.5
20.006		8.0 / 0.5
A = T + (μs) (Cluster 2)		
1000.000		128.0 / 8.0
1000.010		128.0 / 8.0
1000.020		128.0 / 8.0
1000.030		128.0 / 8.0
1000.040		128.0 / 8.0
1000.050		128.0 / 8.0
1000.060		128.0 / 8.0
1000.070		128.0 / 8.0
1000.080		128.0 / 8.0
1000.090		128.0 / 8.0
1000.100		128.0 / 8.0
Customer Existing Index of Refraction: _____		
Main Frame Serial number: _____		
Optical Module Serial number: _____		

APPENDIX A

**TD-285C (1550 nm)
HORIZONTAL SCALE DATA SHEET**

Digital Delay/ Pulse Generator Settings	Test Instrument	
	Indications	Settings
A = T + (μ s) (Cluster 1)	A= (km)	LEN/RES (km / m)
20.000		8.0 / 0.5
20.001		8.0 / 0.5
20.002		8.0 / 0.5
20.003		8.0 / 0.5
20.004		8.0 / 0.5
20.005		8.0 / 0.5
20.006		8.0 / 0.5
A = T + (μ s) (Cluster 2)		
1000.000		128.0 / 8.0
1000.010		128.0 / 8.0
1000.020		128.0 / 8.0
1000.030		128.0 / 8.0
1000.040		128.0 / 8.0
1000.050		128.0 / 8.0
1000.060		128.0 / 8.0
1000.070		128.0 / 8.0
1000.080		128.0 / 8.0
1000.090		128.0 / 8.0
1000.100		128.0 / 8.0
Customer Existing Indexing of Refraction: _____		
Main Frame Serial number: _____		
Optical Module Serial number: _____		

APPENDIX A

**TD-285C (1550 nm)
REFERENCE ATTENUATION DATA SHEET**

(dBm)	
Power High Ref	Power Low Ref
1.	1.
2.	2.
3.	3.

**TD-285C (1550 nm)
REFERENCE CURSOR POSITIONS**

meters	
A =	B =

**TD-285C (1550 nm)
ATTENUATION DATA SHEET**

(dBm)	
Power High	Power Low
1.	1.
2.	2.
3.	3.
4.	4.
5.	5.
6.	6.
7.	7.
8.	8.
9.	9.
Main Frame Serial number: _____	
Optical Module Serial number: _____	

APPENDIX A

**TD-285C (1310 nm)
REFERENCE ATTENUATION DATA SHEET**

(dBm)	
Power High Ref	Power Low Ref
1.	1.
2.	2.
3.	3.

**TD-285C (1310 nm)
REFERENCE CURSOR POSITIONS**

meters	
A =	B =

**TD-285C (1310 nm)
ATTENUATION DATA SHEET**

(dBm)	
Power High	Power Low
1.	1.
2.	2.
3.	3.
4.	4.
5.	5.
6.	6.
7.	7.
8.	8.
9.	9.
Main Frame Serial number: _____	
Optical Module Serial number: _____	

APPENDIX A

**TD-261C (1300 nm)
REFERENCE ATTENUATION DATA SHEET**

(dBm)	
Power High Ref	Power Low Ref
1.	1.
2.	2.
3.	3.

**TD-261C (1300 nm)
REFERENCE CURSOR POSITIONS**

meters	
A =	B =

**TD-261C (1300 nm)
ATTENUATION DATA SHEET**

(dBm)	
Power High	Power Low
1.	1.
2.	2.
3.	3.
4.	4.
5.	5.
6.	6.
7.	7.
8.	8.
9.	9.
Main Frame Serial number: _____	
Optical Module Serial number: _____	

APPENDIX A

**TD-260C (850 nm)
REFERENCE ATTENUATION DATA SHEET**

(dBm)	
Power High Ref	Power Low Ref
1.	1.
2.	2.
3.	3.

**TD-260C (850 nm)
REFERENCE CURSOR POSITIONS**

meters	
A =	B =

**TD-260C (850 nm)
ATTENUATION DATA SHEET**

(dBm)	
Power High	Power Low
1.	1.
2.	2.
3.	3.
4.	4.
5.	5.
6.	6.
7.	7.
8.	8.
9.	9.
Main Frame Serial number: _____	
Optical Module Serial number: _____	

By Order of the Secretary of the Army:

Official:

DENNIS J. REIMER
General, United States Army
Chief of Staff

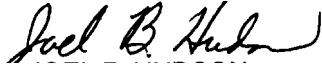

JOEL B. HUDSON
Major General, United States Army
The Adjutant General

02365

Distribution:

To be distributed in accordance with DA Form 12-34-E, Block No. 4581, requirements for calibration procedure TB 9-6625-2309-35